

INSTALLER: LEAVE THIS MANUAL WITH THE APPLIANCE.
CONSUMER: RETAIN THIS MANUAL FOR FUTURE REFERENCE.



INSTALLATION AND OPERATING INSTRUCTIONS

CERTIFIED UNDER CANADIAN AND AMERICAN NATIONAL STANDARDS: ANSI Z21.50 • CSA 2.22 FOR VENTED GAS FIREPLACES.

Vittoria™

GD19N
NATURAL GAS

GD19P
PROPANE

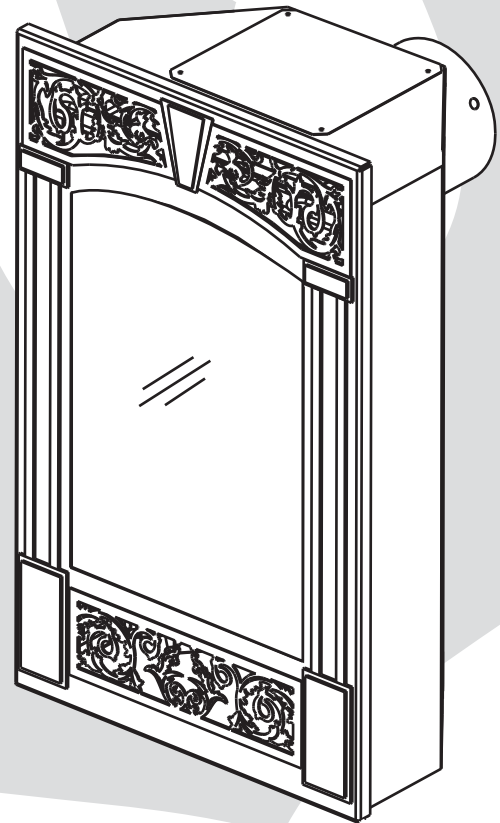

CERTIFIED FOR CANADA AND UNITED STATES USING ANSI/CSA METHODS.

SAFETY INFORMATION

WARNING

If the information in these instructions are not followed exactly, a fire or explosion may result causing property damage, personal injury or loss of life.

- Do not store or use gasoline or other flammable vapors and liquids in the vicinity of this or any other appliance.
- WHAT TO DO IF YOU SMELL GAS:
 - Do not try to light any appliance.
 - Do not touch any electrical switch; do not use any phone in your building.
 - Immediately call your gas supplier from a neighbour's phone. Follow the gas supplier's instructions.
 - If you cannot reach your gas supplier, call the fire department.
- Installation and service must be performed by a qualified installer, service agency or the supplier.



APPLY SERIAL NUMBER LABEL FROM CARTON



Wolf Steel Ltd., 24 Napoleon Rd., Barrie, ON, L4M 4Y8 Canada /
103 Miller Drive, Crittenden, Kentucky, USA, 41030
Phone (705)721-1212 • Fax (705)722-6031 • www.napoleonfireplaces.com • ask@napoleon.on.ca

TABLE OF CONTENTS

1.0	INTRODUCTION	3
1.1	WARRANTY	4
1.2	DIMENSIONS	5
1.3	INSTALLATION OVERVIEW	6
1.4	GENERAL INSTRUCTIONS	7
1.5	GENERAL INFORMATION	8
1.6	CARE OF GLASS	8
2.0	VENTING	9
2.1	VENTING LENGTHS AND COMPONENTS	9
2.2	TYPICAL VENT INSTALLATION	10
2.3	SPECIAL VENT INSTALLATIONS	12
2.3.1	PERISCOPE TERMINATION	12
2.3.2	CORNER TERMINATION	12
2.4	MINIMUM AIR TERMINAL LOCATION CLEARANCES	13
2.5	VENTING APPLICATION FLOW CHART	14
2.6	DEFINITIONS	14
2.7	ELBOW VENT LENGTH VALUES	15
2.8	TOP EXIT HORIZONTAL TERMINATION	15
2.9	REAR EXIT HORIZONTAL TERMINATION	17
2.10	TOP OR REAR EXIT VERTICAL TERMINATION	19
2.11	REAR VENT CONVERSION	22
3.0	INSTALLATION	23
3.1	WALL AND CEILING PROTECTION	23
3.1.1	HORIZONTAL INSTALLATION	24
3.1.2	VERTICAL INSTALLATION	24
3.2	USING FLEXIBLE VENT COMPONENTS	25
3.2.1	HORIZONTAL AIR TERMINAL INSTALLATION	25
3.2.2	VERTICAL AIR TERMINAL INSTALLATION	26
3.2.3	APPLIANCE VENT CONNECTION	26
3.3	USING RIGID VENT COMPONENTS	27
3.3.1	HORIZONTAL AIR TERMINAL INSTALLATION	27
3.3.2	EXTENDED HORIZONTAL AND CORNER AIR TERMINAL INSTALLATION	27
3.3.3	VERTICAL AIR TERMINAL INSTALLATION	28
3.3.4	RESTRICTING VERTICAL VENTS	29
3.4	MOBILE HOME INSTALLATION	29
3.5	GAS INSTALLATION	30
3.6	OPTIONAL WALL SWITCH	30
4.0	FRAMING	31
4.1	MINIMUM CLEARANCE TO COMBUSTIBLES	31
4.1.1	REAR VENT	33
4.1.2	TOP VENT	33
4.2	MINIMUM CLEARANCE TO COMBUSTIBLE ENCLOSURES	34
4.3	MINIMUM MANTEL CLEARANCES	35
5.0	ELECTRICAL CONNECTION	36
6.0	WIRING DIAGRAM	37
7.0	FINISHING	38
7.1	GLASS DOOR	38
7.2	DOOR GLASS REPLACEMENT	38
7.3	LOG PLACEMENT	39
7.4	CHARCOAL EMBERS	39
7.5	VERMICULITE	39
7.6	GLOWING EMBERS	40
7.7	LOGO PLACEMENT	40
7.8	FRONT FACING AND INSET KIT INSTALLATION	40
8.0	OPTIONAL BLOWER INSTALLATION	42
9.0	OPERATION	43
9.1	CONTROL FUNCTIONS	44
10.0	ADJUSTMENTS	44
10.1	PILOT INJECTOR AND ORIFICE REPLACEMENT	44
10.2	PRESSURE CHECK	45
10.3	FLAME ADJUSTMENT	45
10.4	FLAME CHARACTERISTICS	45
10.5	VENTURI ADJUSTMENT	45
11.0	MAINTENANCE	46
11.1	NIGHT LIGHT™ REPLACEMENT	46
11.1.1	BULB REPLACEMENT	46
11.1.2	LENS ASSEMBLY INSTALLATION	46
11.1.3	LENS ASSEMBLY REPLACEMENT	46
12.0	REPLACEMENTS	47
13.0	TROUBLE SHOOTING	50
14.0	SERVICE HISTORY	52

NOTE: Changes, other than editorial, are denoted by a vertical line in the margin.

1.0 INTRODUCTION

WARNING

- Do not operate appliance before reading and understanding operating instructions. Failure to operate appliance according to operating instructions could cause fire or injury.
- Risk of fire or asphyxiation do not operate appliance with fixed glass removed.
- Do not connect 110 volts to the control valve.
- Risk of burns. The appliance should be turned off and cooled before servicing.
- Do not install damaged, incomplete or substitute components.
- Risk of cuts and abrasions. Wear protective gloves and safety glasses during installation. Sheet metal edges may be sharp.
- Do not burn wood or other materials in this appliance.
- Young children should be carefully supervised when they are in the same room as the appliance. Toddlers, young children and others may be susceptible to accidental contact burns. A physical barrier is recommended if there are at risk individuals in the house. To restrict access to an appliance or stove, install an adjustable safety gate to keep toddlers, young children and other at risk individuals out of the room and away from hot surfaces.
- Clothing or other flammable material should not be placed on or near the appliance.
- Due to high temperatures, the appliance should be located out of traffic and away from furniture and draperies.
- Ensure you have incorporated adequate safety measure to protect infants/toddlers from touching hot surfaces.
- Even after the appliance is out, the glass and/or screen will remain hot for an extended period of time.
- Check with your local hearth specialty dealer for safety screens and hearth guards to protect children from hot surfaces. These screens and guards must be fastened to the floor.
- Any safety screen or guard removed for servicing must be replaced prior to operating the appliance.
- It is imperative that the control compartments, burners and circulating blower and its passageway in the appliance and venting system are kept clean. The appliance and its venting system should be inspected before use and at least annually by a qualified service person. More frequent cleaning may be required due to excessive lint from carpeting, bedding material, etc. The appliance area must be kept clear and free from combustible materials, gasoline and other flammable vapors and liquids.
- Under no circumstances should this appliance be modified.
- This appliance must not be connected to a chimney flue pipe serving a separate solid fuel burning appliance.
- Do not use this appliance if any part has been under water. Immediately call a qualified service technician to inspect the appliance and to replace any part of the control system and any gas control which has been under water.
- Do not operate the appliance with the glass door removed, cracked or broken. Replacement of the glass should be done by a licensed or qualified service person.
- Do not strike or slam shut the appliance glass door.
- When equipped with pressure relief doors, they must be kept closed while the appliance is operating to prevent exhaust fumes containing carbon monoxide, from entering into the home. Temperatures of the exhaust escaping through these openings can also cause the surrounding combustible materials to overheat and catch fire.
- Only doors / optional fronts certified with the unit are to be installed on the appliance.
- Keep the packaging material out of reach of children and dispose of the material in a safe manner. As with all plastic bags, these are not toys and should be kept away from children and infants.
- As with any combustion appliance, we recommend having your appliance regularly inspected and serviced as well as having a Carbon Monoxide Detector installed in the same area to defend you and your family against Carbon Monoxide.

3.2

1.1 WARRANTY

NAPOLEON® products are manufactured under the strict Standard of the world recognized ISO 9001 : 2000 Quality Assurance Certificate.

NAPOLEON® products are designed with superior components and materials assembled by trained craftsmen who take great pride in their work. The burner and valve assembly are leak and test-fired at a quality test station. The complete heater is again thoroughly inspected by a qualified technician before packaging to ensure that you, the customer, receives the quality product that you expect from NAPOLEON®.

NAPOLEON® GAS FIREPLACE PRESIDENT'S LIFETIME LIMITED WARRANTY

The following materials and workmanship in your new NAPOLEON® gas heater are warranted against defects for as long as you own the heater. This covers: combustion chamber, heat exchanger, stainless steel burner, phazer™ logs and embers, rocks, ceramic glass (thermal breakage only), gold plated parts against tarnishing, porcelainized enameled components and aluminum extrusion trims.* Electrical (110V and millivolt) components and wearable parts such as blowers, gas valves, thermal switch, switches, wiring, remote controls, ignitor, gasketing, and pilot assembly are covered and NAPOLEON® will provide replacement parts free of charge during the first year of the limited warranty.* Labour related to warranty repair is covered free of charge during the first year. Repair work, however, requires the prior approval of an authorized company official. Labour costs to the account of NAPOLEON® are based on a predetermined rate schedule and any repair work must be done through an authorized NAPOLEON® dealer.

* Construction of models vary. Warranty applies only to components included with your specific heater.

CONDITIONS AND LIMITATIONS

NAPOLEON® warrants its products against manufacturing defects to the original purchaser only. Registering your warranty is not necessary. Simply provide your proof of purchase along with the model and serial number to make a warranty claim. NAPOLEON® reserves the right to have its representative inspect any product or part thereof prior to honouring any warranty claim. Provided that the purchase was made through an authorized NAPOLEON® dealer your heater is subject to the following conditions and limitations:

This factory warranty is non-transferable and may not be extended whatsoever by any of our representatives.

The gas heater must be installed by a licensed, authorized service technician or contractor. Installation must be done in accordance with the installation instructions included with the product and all local and national building and fire codes. This limited warranty does not cover damages caused by misuse, lack of maintenance, accident, alterations, abuse or neglect and parts installed from other manufacturers will nullify this warranty.

This limited warranty further does not cover any scratches, dents, corrosion or discoloring caused by excessive heat, abrasive and chemical cleaners nor chipping on porcelain enamel parts, mechanical breakage of PHAZER™ logs and embers.

NAPOLEON® warrants its stainless steel burners against defects in workmanship and material for life, subject to the following conditions: During the first 10 years NAPOLEON® will replace or repair the defective parts at our option free of charge. From 10 years to life, NAPOLEON® will provide replacement burners at 50% of the current retail price.

In the first year only, this warranty extends to the repair or replacement of warranted parts which are defective in material or workmanship provided that the product has been operated in accordance with the operation instructions and under normal conditions.

After the first year, with respect to this President's Lifetime Limited Warranty, NAPOLEON® may, at its discretion, fully discharge all obligations with respect to this warranty by refunding to the original warranted purchaser the wholesale price of any warranted but defective part(s).

NAPOLEON® will not be responsible for installation, labour or any other expenses related to the reinstallation of a warranted part and such expenses are not covered by this warranty.

Notwithstanding any provisions contained in the President's Lifetime Limited Warranty, NAPOLEON'S responsibility under this warranty is defined as above and it shall not in any event extend to any incidental, consequential or indirect damages.

This warranty defines the obligations and liability of NAPOLEON® with respect to the NAPOLEON® gas heater and any other warranties expressed or implied with respect to this product, its components or accessories are excluded.

NAPOLEON® neither assumes, nor authorizes any third party to assume, on its behalf, any other liabilities with respect to the sale of this product.

NAPOLEON® will not be responsible for: over-firing, downdrafts, spillage caused by environmental conditions such as rooftops, buildings, nearby trees, hills, mountains, inadequate vents or ventilation, excessive venting configurations, insufficient makeup air, or negative air pressures which may or may not be caused by mechanical systems such as exhaust fans, furnaces, clothes dryers, etc.

Any damages to heater, combustion chamber, heat exchanger, brass trim or other components due to water, weather damage, long periods of dampness, condensation, damaging chemicals or cleaners will not be the responsibility of NAPOLEON®.

ALL SPECIFICATIONS AND DESIGNS ARE SUBJECT TO CHANGE WITHOUT PRIOR NOTICE DUE TO ON-GOING PRODUCT IMPROVEMENTS. NAPOLEON® IS A REGISTERED TRADEMARK OF WOLF STEEL LTD. PATENTS U.S. 5.303.693.801 - CAN. 2.073.411, 2.082.915. © WOLF STEEL LTD.

1.2 DIMENSIONS

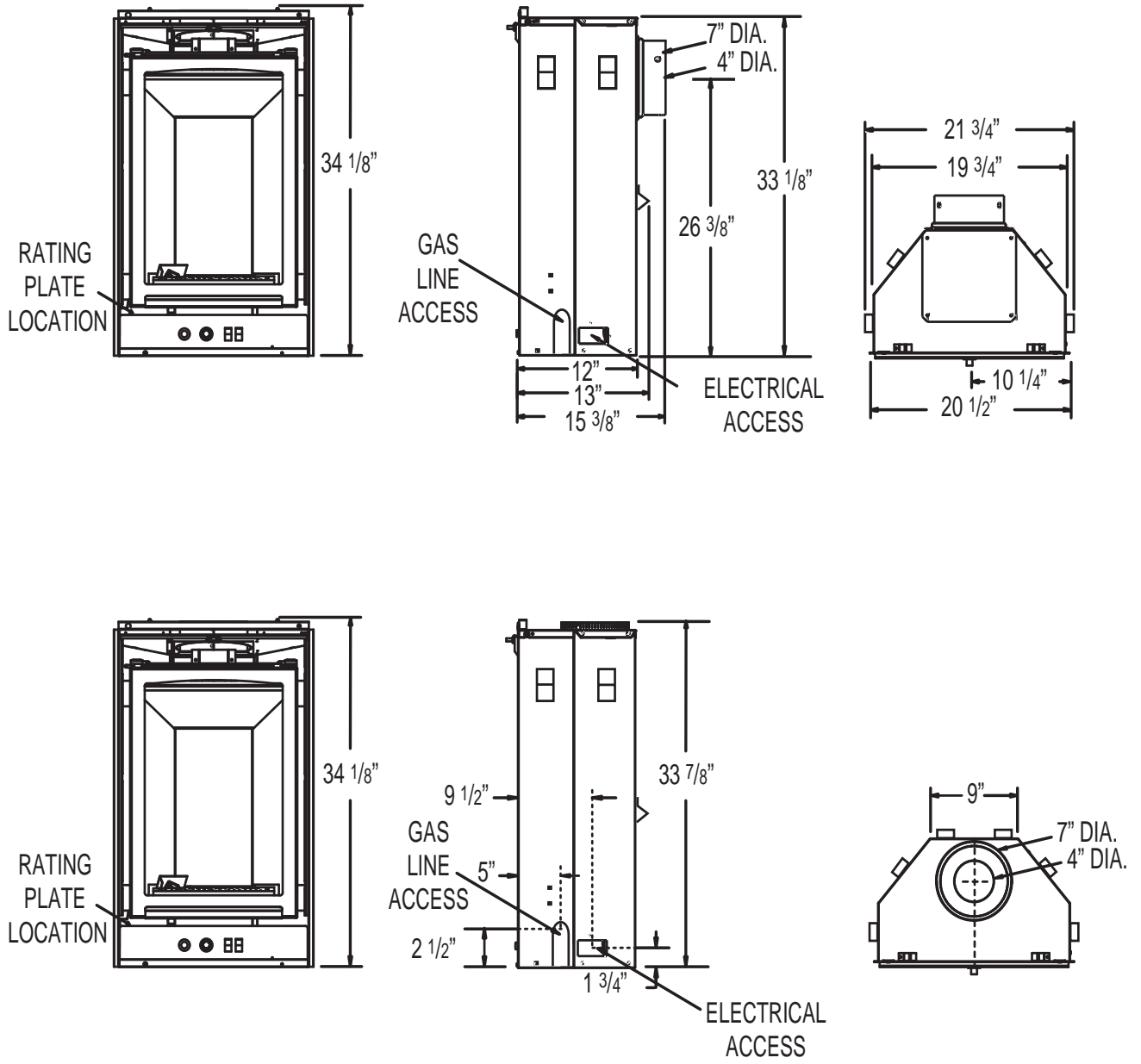

1.3 INSTALLATION OVERVIEW

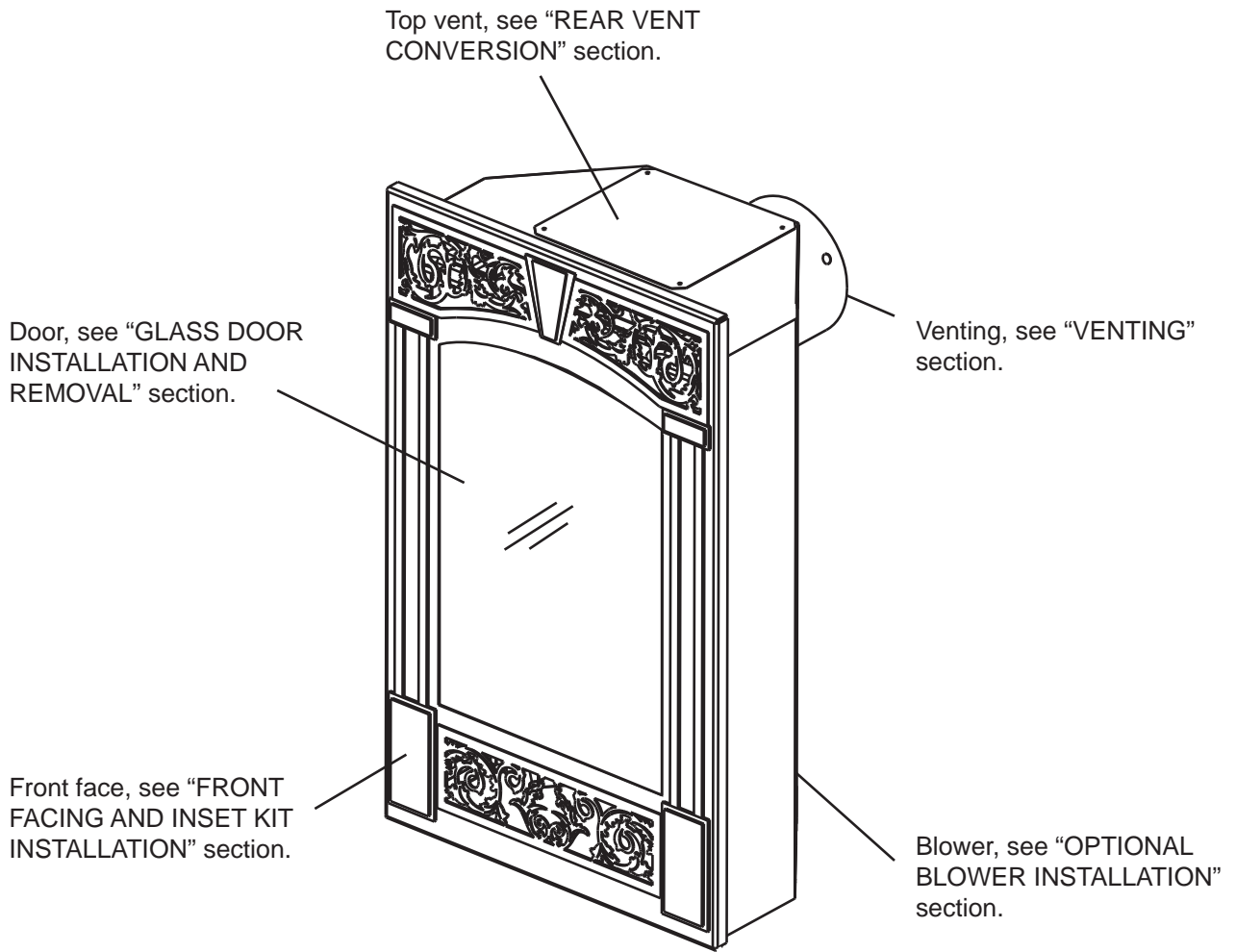

1.4 GENERAL INSTRUCTIONS

! WARNING
ALWAYS LIGHT THE PILOT WHETHER FOR THE FIRST TIME OR IF THE GAS SUPPLY HAS RAN OUT, WITH THE GLASS DOOR OPENED OR REMOVED.
PROVIDE ADEQUATE CLEARANCE FOR SERVICING AND OPERATING THE APPLIANCE.
PROVIDE ADEQUATE VENTILATION.
NEVER OBSTRUCT THE FRONT OPENING OF THE APPLIANCE.
OBJECTS PLACED IN FRONT OF THE APPLIANCE MUST BE KEPT A MINIMUM OF 48" FROM THE FRONT FACE OF THE UNIT.
FIRE RISK. EXPLOSION HAZARD.
HIGH PRESSURE WILL DAMAGE VALVE. DISCONNECT GAS SUPPLY PIPING BEFORE PRESSURE TESTING GAS LINE AT TEST PRESSURES ABOVE 1/2 PSIG. CLOSE THE MANUAL SHUT-OFF VALVE BEFORE PRESSURE TESTING GAS LINE AT TEST PRESSURES EQUAL TO OR LESS THAN 1/2 PSIG.
USE ONLY WOLF STEEL APPROVED OPTIONAL ACCESSORIES AND REPLACEMENT PARTS WITH THIS APPLIANCE. USING NON-LISTED ACCESSORIES (BLOWERS, DOORS, LOUVRES, TRIMS, GAS COMPONENTS, VENTING COMPONENTS, ETC.) COULD RESULT IN A SAFETY HAZARD AND WILL VOID THE WARRANTY AND CERTIFICATION.

THIS GAS APPLIANCE SHOULD BE INSTALLED AND SERVICED BY A QUALIFIED INSTALLER to conform with local codes. Installation practices vary from region to region and it is important to know the specifics that apply to your area, for example in Massachusetts State: This product must be installed by a licensed plumber or gas fitter when installed within the commonwealth of Massachusetts.

- The appliance damper must be removed or welded in the open position prior to installation of a appliance insert or gas log.
- The appliance off valve must be a "T" handle gas cock.
- The flexible connector must not be longer than 36 inches.
- A Carbon Monoxide detector is required in all rooms containing gas fired appliances.
- The appliance is not approved for installation in a bedroom or bathroom unless the unit is a direct vent sealed combustion product.

The installation must conform with local codes or, in absence of local codes, the National Gas and Propane Installation Code CSA B149.1 in Canada, or the National Fuel Gas Code, ANSI Z223.1 / NFPA 54 in the United States. Suitable for mobile home installation if installed in accordance with the current standard CAN/CSA Z240MH Series, for gas equipped mobile homes, in Canada or ANSI Z223.1 and NFPA 54 in the United States.



As long as the required clearance to combustibles is maintained, the most desirable and beneficial location for an appliance is in the center of a building, thereby allowing the most efficient use of the heat created. The location of windows, doors and the traffic flow in the room where the appliance is to be located should be considered. If possible, you should choose a location where the vent will pass through the house without cutting a floor or roof joist.

When the appliance is installed directly on carpeting, vinyl tile or other combustible material other than wood flooring, the appliance shall be installed on a metal or wood panel extending the full width and depth.

If the optional fan or blower is installed, the junction box must be electrically connected and grounded in accordance with local codes. In the absence of local codes, use the current CSA C22.1 Canadian Electrical Code in Canada or the ANSI/NFPA 70 National Electrical Code in the United States.

1.5 GENERAL INFORMATION

FOR YOUR SATISFACTION, THIS APPLIANCE HAS BEEN TEST-FIRED TO ASSURE ITS OPERATION AND QUALITY!

MINIMUM INLET: Gas supply pressure is 4.5 inches water column for natural gas and 11 inches water column for propane.

MAXIMUM INLET: Gas pressure is 7 inches water column for natural gas and 13 inches water column for propane. When the valve is set to "HI", the manifold pressure under flow conditions is 3.5 inches water column for natural gas and 10 inches water column for propane. When the appliance is installed at elevations above 4,500ft, and in the absence of specific recommendations from the local authority having jurisdiction, the certified high altitude input rating shall be reduced at the rate of 4% for each additional 1,000ft.

Expansion / contraction noises during heating up and cooling down cycles are normal and to be expected.

This appliance is only for use with the type of gas indicated on the rating plate. This appliance is not convertible for use with other gases, unless a certified kit is used.

MAXIMUM INPUT: Is 11,500 BTU/hr for natural gas.

MAXIMUM OUTPUT: Is 8,600 BTU/hr at an efficiency of 75%.

MAXIMUM INPUT: Is 11,000 BTU/hr for propane.

MAXIMUM OUTPUT: Is 8,250 BTU/hr at an efficiency of 75%.

Provide adequate accessibility clearance for servicing and operating the appliance.

Never obstruct the front opening of the appliance.

RATING LABEL LOCATION: The rating label is located behind the control door and is chained to the appliance. **DO NOT REMOVE.**

1.6 CARE OF GLASS

DO NOT CLEAN GLASS WHEN HOT! DO NOT USE ABRASIVE CLEANERS TO CLEAN GLASS.

Buff lightly with a clean dry soft cloth. Clean the glass after the first 10 hours of operation with a recommended fireplace glass cleaner. Thereafter clean as required. If the glass is not kept clean permanent discoloration and / or blemishes may result.



2.0 VENTING

WARNING

RISK OF FIRE, MAINTAIN SPECIFIED AIR SPACE CLEARANCES TO VENT PIPE AND APPLIANCE.

THE VENT SYSTEM MUST BE SUPPORTED EVERY 3 FEET FOR BOTH VERTICAL AND HORIZONTAL RUNS. USE SUPPORTS OR EQUIVALENT NON-COMBUSTIBLE STRAPPING TO MAINTAIN THE REQUIRED CLEARANCE FROM COMBUSTIBLES. SPACERS ARE ATTACHED TO THE INNER FLEX PIPE AT PREDETERMINED INTERVALS TO MAINTAIN AN EVEN AIR GAP TO THE OUTER FLEX PIPE. THIS GAP IS REQUIRED FOR SAFE OPERATION. A SPACER IS REQUIRED AT THE START, MIDDLE AND END OF EACH ELBOW TO ENSURE THIS GAP IS MAINTAINED. THESE SPACERS MUST NOT BE REMOVED.

**THIS APPLIANCE USES A 4" EXHAUST / 7" AIR INTAKE VENT PIPE SYSTEM.
Refer to the section applicable to your installation.**

For safe and proper operation of the appliance follow the venting instruction exactly. Deviation from the minimum vertical vent length can create difficulty in burner start-up and/or carboning. Under extreme vent configurations, allow several minutes (5-15) for the flame to stabilize after ignition. Vent lengths that pass through unheated spaces (attics, garages, crawl spaces) should be insulated with the insulation wrapped in a protective sleeve to minimize condensation. Provide a means for visually checking the vent connection to the appliance after the appliance is installed. Use a firestop, vent pipe shield or attic insulation shield when penetrating interior walls, floor or ceiling.

NOTE: If for any reason the vent air intake system is disassembled; reinstall per the instructions provided for the initial installation.

7.1

2.1 VENTING LENGTHS AND COMPONENTS

Use only Wolf Steel, Simpson Dura-Vent, Selkirk Direct Temp, American Metal Amerivent or Metal-Fab venting components. Minimum and maximum vent lengths, for both horizontal and vertical installations, and air terminal locations for either system are set out in this manual and must be adhered to. For Simpson Dura-Vent, Selkirk Direct Temp, American Metal Amerivent and Metal-Fab follow the installation procedure provided with the venting components.

A starter adaptor must be used with the following vent systems and may be purchased from the corresponding supplier:

PART	4"/7"	SUPPLIER	WEBSITE
Duravent	W175-0053	Wolf Steel	www.duravent.com
Amerivent	4DSC-N2	American Metal	www.americanmetalproducts.com
Direct Temp	4DT-AAN	Selkirk	www.selkirkcorp.com
SuperSeal	4DNA	Metal-Fab	www.mtlfab.com

*** For Simpson Dura-Vent, Selkirk Direct Temp, American Metal Amerivent and Metal-Fab follow the installation procedure found on the website for your venting supplier.**

For vent systems that provide seals on the inner exhaust flue, only the outer air intake joints must be sealed using a red high temperature silicone (RTV). This same sealant may be used on both the inner exhaust and outer intake vent pipe joints of all other approved vent systems except for the exhaust vent pipe connection to the appliance flue collar which must be sealed using the black high temperature sealant Mill Pac.

When using Wolf Steel venting components, use only approved Wolf Steel rigid / flexible components with the following termination kits: wall terminal kit **GD222**, **GD222R**, or 1/12 to 7/12 pitch roof terminal kit **GD110**, 8/12 to 12/12 roof terminal kit **GD111**, flat roof terminal kit **GD112** or periscope kit **GD201** (for wall penetration below grade). With flexible venting, in conjunction with the various terminations, use either the 5 foot vent kit **GD220** or the 10 foot vent kit **GD330**.

For optimum flame appearance and appliance performance, keep the vent length and number of elbows to a minimum. The air terminal must remain unobstructed at all times. Examine the air terminal at least once a year to verify that it is unobstructed and undamaged. Rigid and flexible venting systems must not be combined. Different venting manufacturer components must not be combined.

These vent kits allow for either horizontal or vertical venting of the appliance. The maximum allowable horizontal run is 20 feet. The maximum allowable vertical vent length is 40 feet. The maximum number of vent connections is two horizontally or three vertically (excluding the appliance and the air terminal connections) when using flexible venting.

8.1

2.2 TYPICAL VENT INSTALLATION

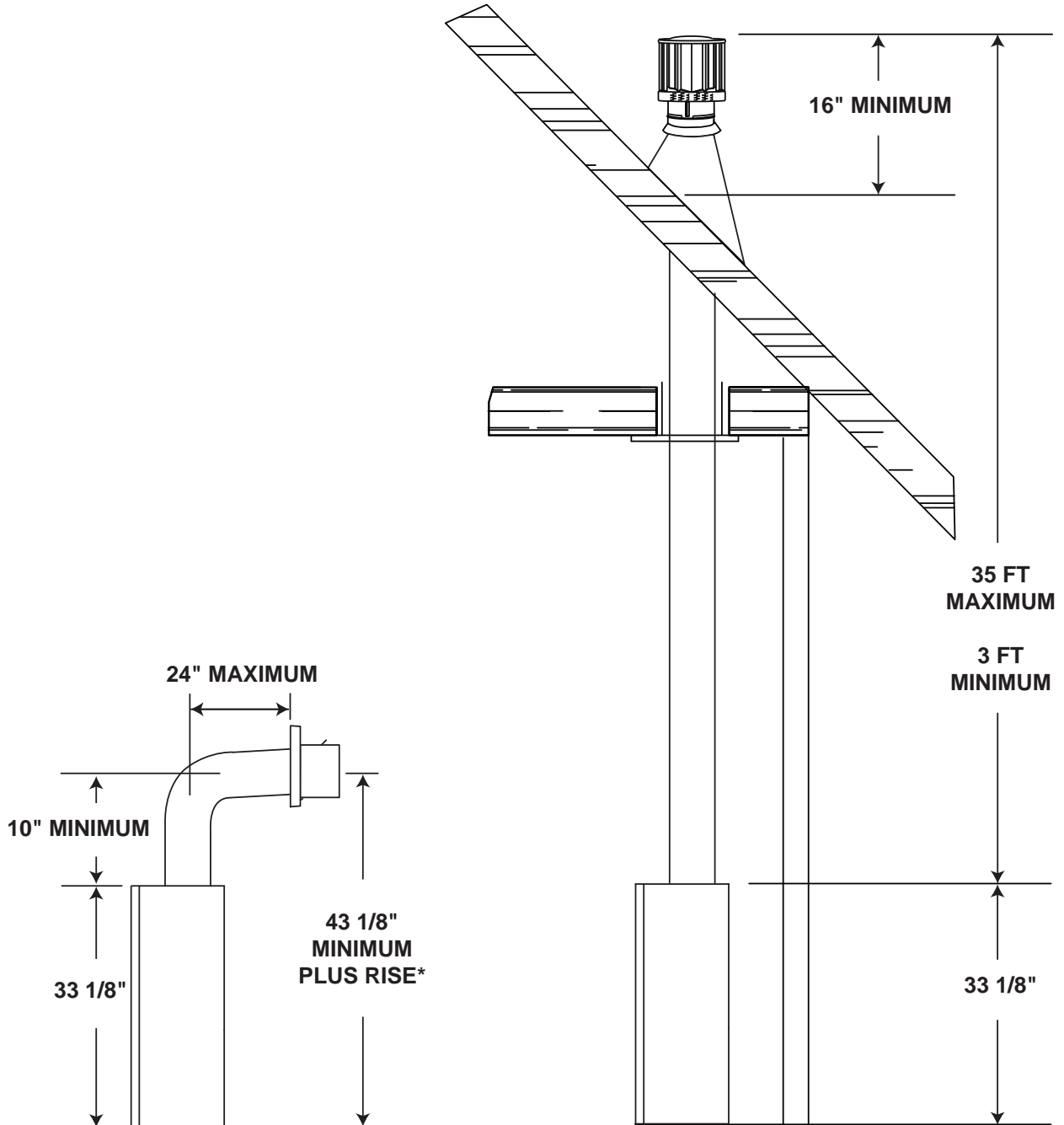

* See "VENTING" section

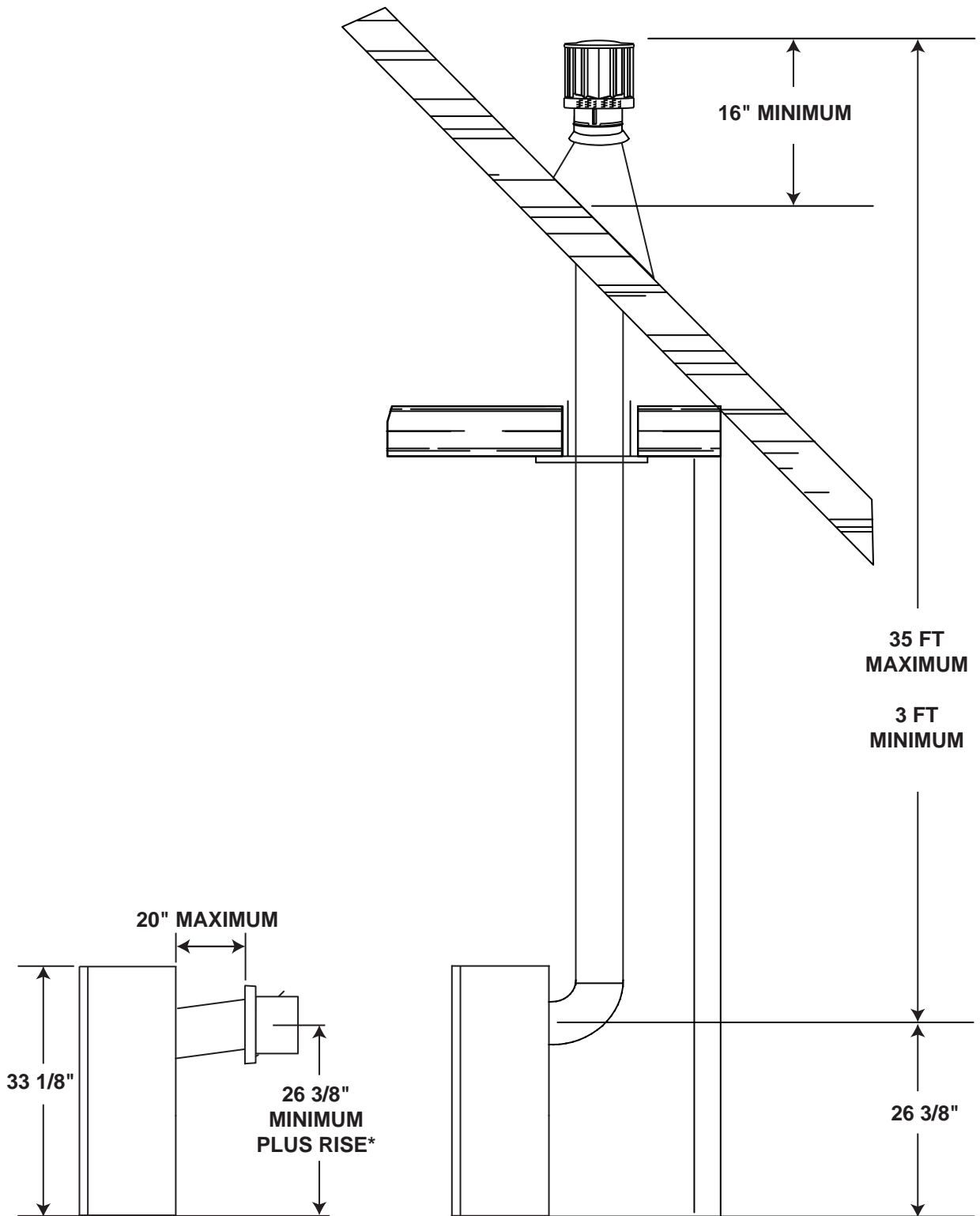

* See "VENTING" section

2.3 SPECIAL VENT INSTALLATIONS

2.3.1 PERISCOPE TERMINATION

Use the periscope kit to locate the air termination above grade. The periscope must be installed so that when final grading is completed, the bottom air slot is located a minimum 12" above grade. The maximum allowable vent length is 10'.

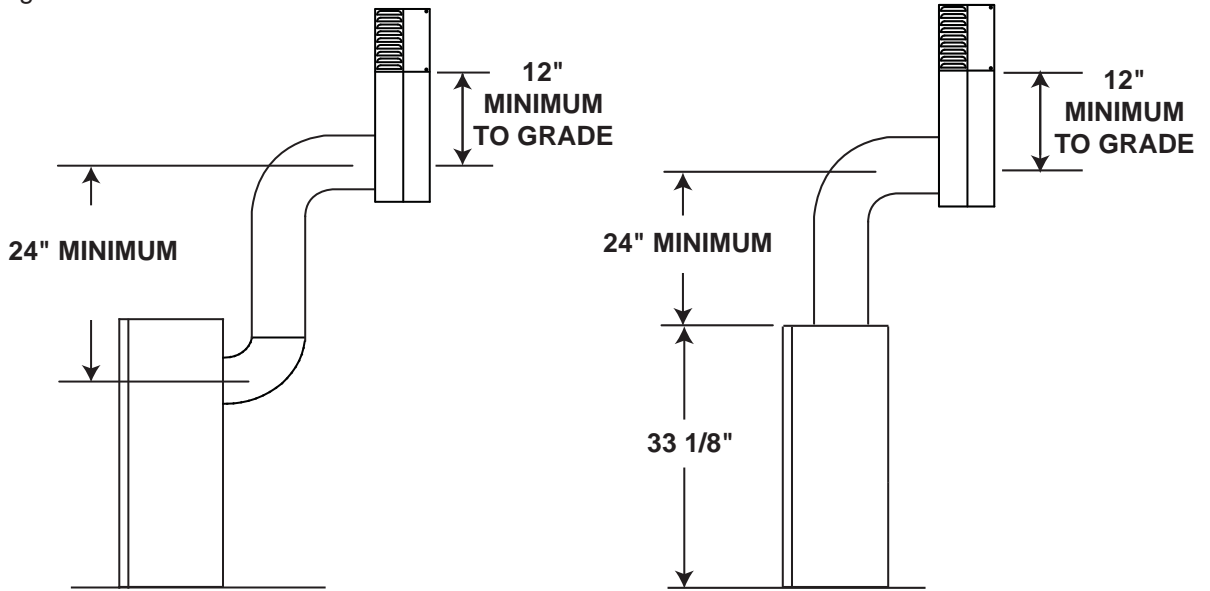

9.4

2.3.2 CORNER TERMINATION

The maximum vent length for a corner installation is 20" of horizontal run, in addition to the 45° offset. In this case zero rise is acceptable. See illustrations below. It is recommended to maintain a 6" rise.

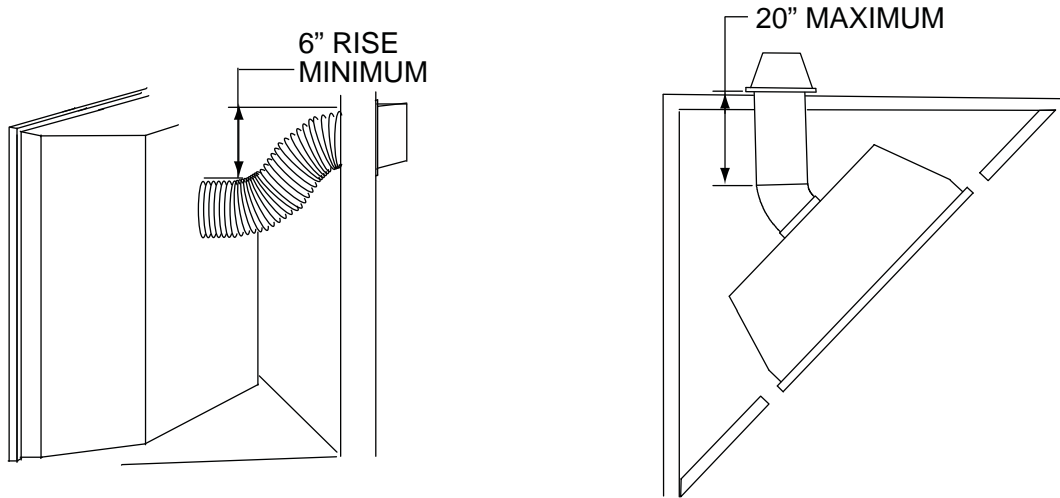

2.4 MINIMUM AIR TERMINAL LOCATION CLEARANCES

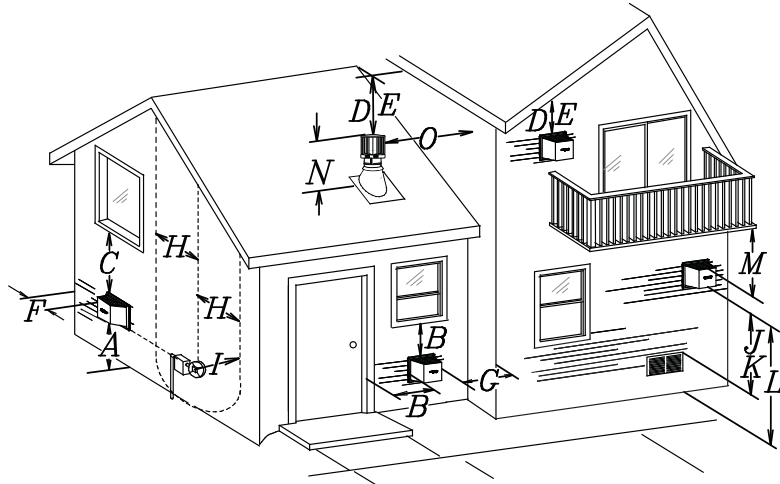

INSTALLATIONS			
	CANADA	U.S.A.	
A	12"	12"	Clearance above grade, veranda porch, deck or balcony.
B	12"	9"	Clearance to windows or doors that open.
C	12" *	12" *	Clearance to permanently closed windows.
D	18" **	18" **	Vertical clearance to ventilated soffits located above the terminal within a horizontal distance of 2' from the centerline of the terminal.
E	18" **	18" **	Clearance to unventilated soffit.
F	0"	0"	Clearance to an outside corner wall.
G	0" ***	0" ***	Clearance to an inside non-combustible corner wall or protruding non-combustible obstructions (chimney, etc.).
	2" ***	2" ***	Clearance to an inside combustible corner wall or protruding combustible obstructions (vent chase, etc.).
H	3'	3' ****	Clearance to each side of the centerline extended above the meter / regulator assembly to a maximum vertical distance of 15'.
I	3'	3' ****	Clearance to a service regulator vent outlet.
J	12"	9"	Clearance to a non-mechanical air supply inlet to the building or a combustion air inlet to any other appliance.
K	6'	3' †	Clearance to a mechanical air supply inlet.
L	7' ‡	7' ****	Clearance above a paved sidewalk or paved driveway located on public property.
M	12" ††	12" ****	Clearance under a veranda, porch, deck or balcony.
N	16"	16"	Clearance above the roof.
O	2' †*	2' †*	Clearance from an adjacent wall including neighbouring buildings.
*	Recommended to prevent condensation on windows and thermal breakage		
**	It is recommended to use a heat shield and to maximize the distance to vinyl clad soffits.		
***	The periscope requires a minimum 18" clearance from an inside corner.		
****	This is a recommended distance. For additional requirements check local codes.		
†	3 feet above if within 10 feet horizontally.		
‡	A vent shall not terminate directly above a sidewalk or paved driveway that is located between two single family dwellings and serves both dwellings.		
††	Permitted only if the veranda, porch, or deck is fully open on a minimum of two sides beneath the floor.		
†*	Recommended to prevent recirculation of exhaust products. For additional requirements check local codes.		

NOTE: Clearances are in accordance with local installation codes and the requirements of the gas supplier.

2.5 VENTING APPLICATION FLOW CHART

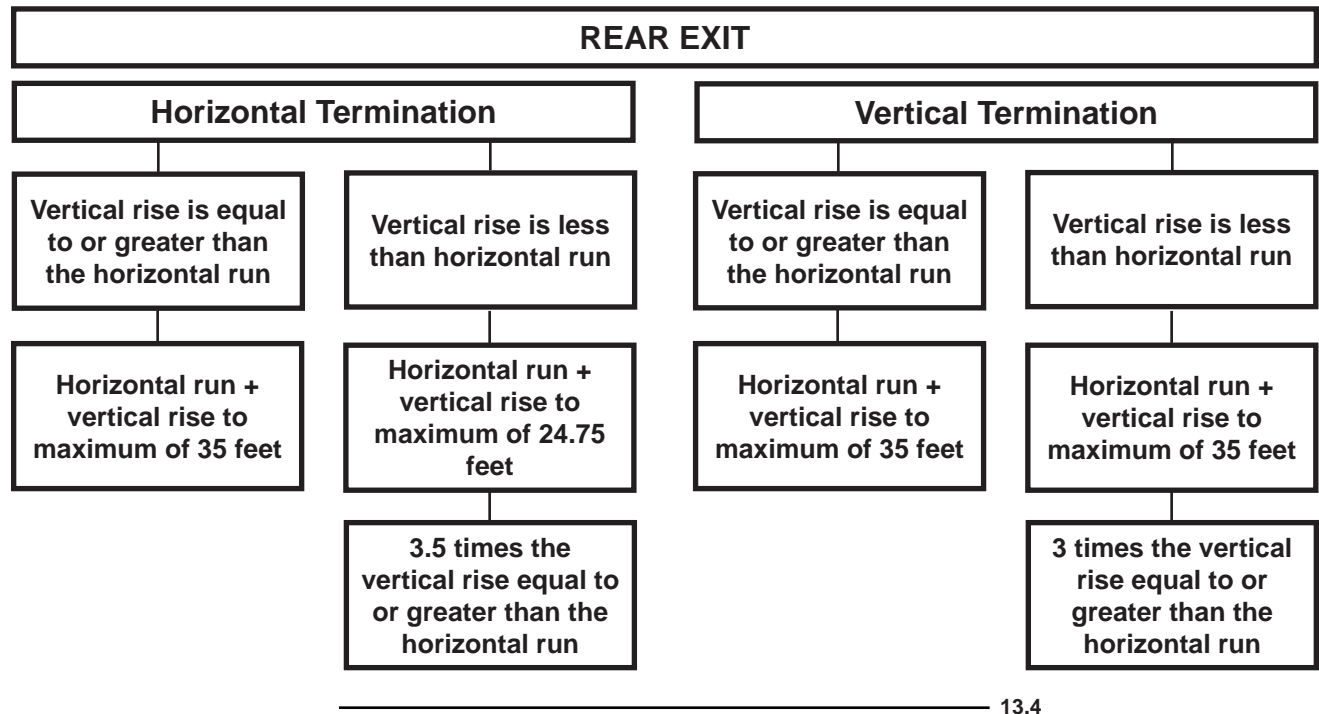
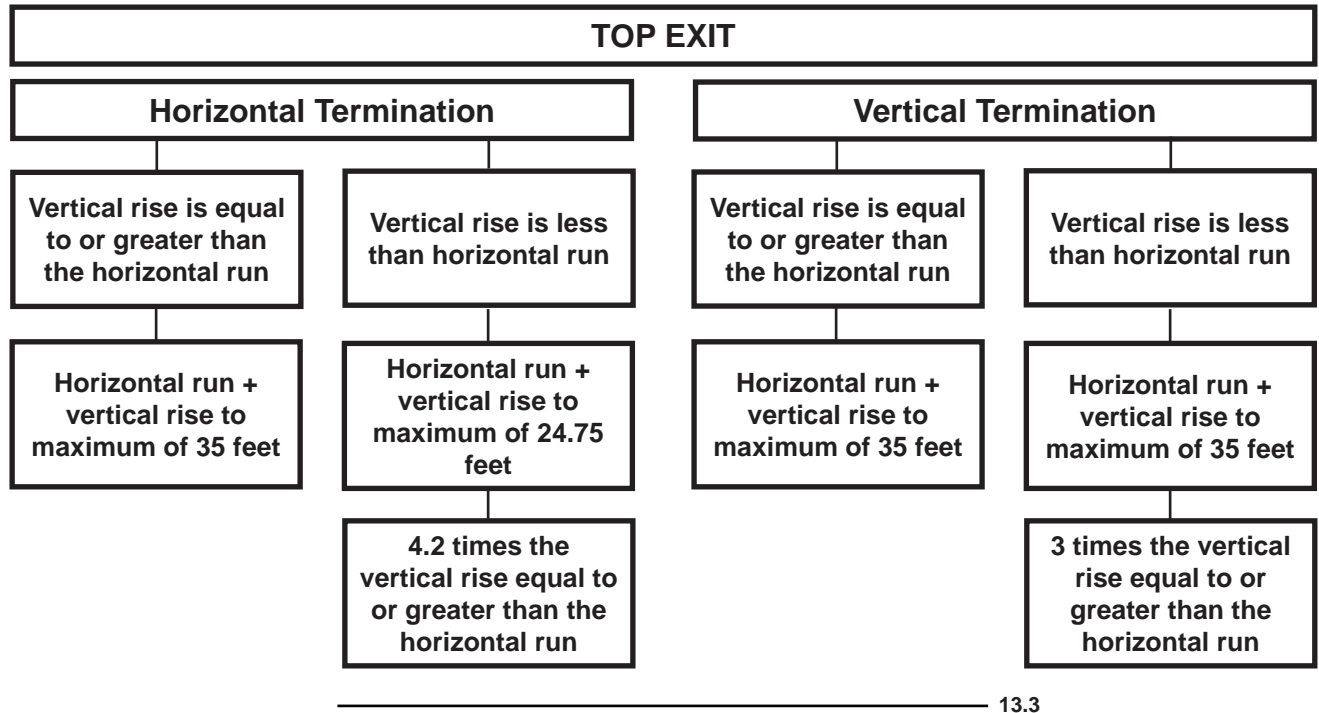

2.6 DEFINITIONS

For the following symbols used in the venting calculations and examples are:

- > - greater than
- ≥ - equal to or greater than
- < - less than
- ≤ - equal to or less than
- H_T - total of both horizontal vent lengths (H_r) and offsets (H_o) in feet
- H_R - combined horizontal vent lengths in feet
- H_O - offset factor: .03 (total degrees of offset - 90°*) in feet
- V_T - combined vertical vent lengths in feet

2.7 ELBOW VENT LENGTH VALUES

	<u>FEET</u>	<u>INCHES</u>
1°	0.03	0.5
15°	0.45	6.0
30°	0.9	11.0
45°	1.35	16.0
90°*	2.7	32.0

* The first 90° offset has a zero value and is shown in the formula as - 90°

15.1

2.8 TOP EXIT HORIZONTAL TERMINATION

$$(H_T) \leq (V_T)$$

Simple venting configuration (only one 90° elbow)

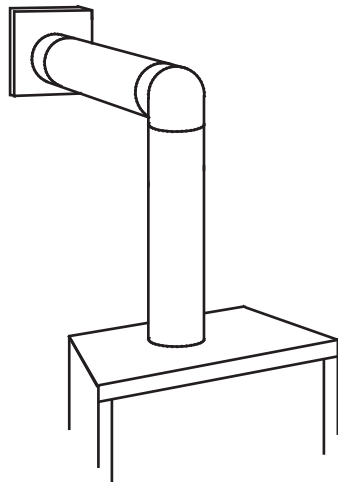

See graph to determine the required vertical rise V_T for the required horizontal run H_T .

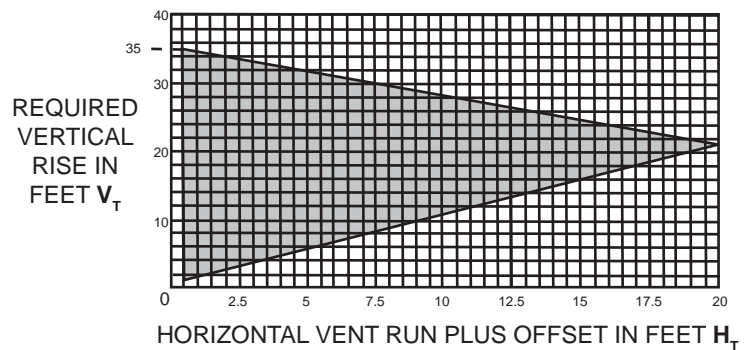

The shaded area within the lines represents acceptable values for H_T and V_T

For vent configurations requiring more than one 90° elbow, the following formulas apply:

Formula 1: $H_T \leq V_T$

Formula 2: $H_T + V_T \leq 35$ feet

Example 1:

$V_1 = 3$ FT

$V_2 = 8$ FT

$V_T = V_1 + V_2 = 3 + 8 = 11$ FT

$H_1 = 2.5$ FT

$H_2 = 2$ FT

$H_R = H_1 + H_2 = 2.5 + 2 = 4.5$ FT

$H_o = .03$ (three 90° elbows - 90°) = .03 (270° - 90°) = 5.4 FT

$H_T = H_R + H_o = 4.5 + 5.4 = 9.9$ FT

$H_T + V_T = 9.9 + 11 = 20.9$ FT

Formula 1: $H_T \leq V_T$
 $9.9 \leq 11$

Formula 2: $H_T + V_T \leq 35$ FT
 $20.9 \leq 35$

Since both formulas are met, this vent configuration is acceptable.

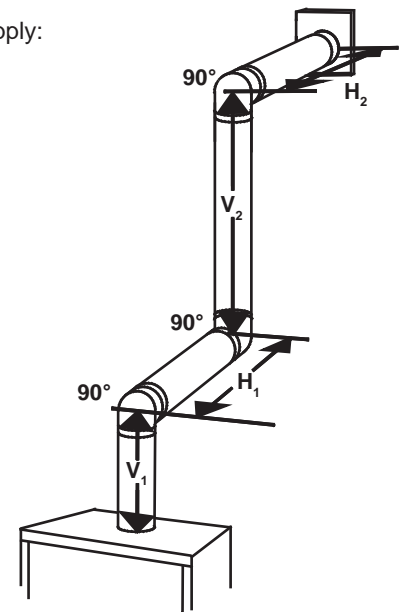

16.6

$$(H_T) > (V_T)$$

Simple venting configuration (only one 90° elbow)

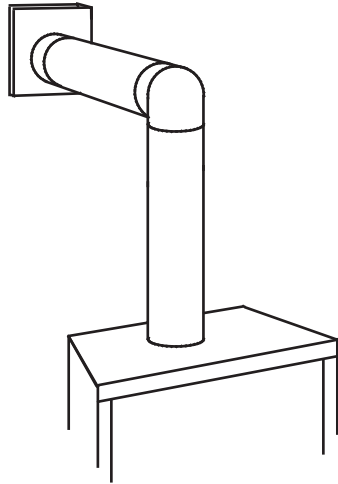

See graph to determine the required vertical rise V_T for the required horizontal run H_T .

REQUIRED VERTICAL RISE IN INCHES V_T

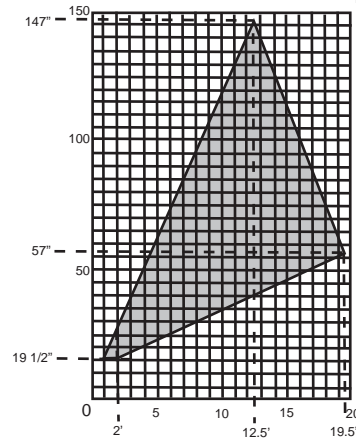

HORIZONTAL VENT RUN PLUS OFFSET IN FEET H_T

The shaded area within the lines represents acceptable values for H_T and V_T

For vent configurations requiring more than one 90° elbow, the following formulas apply:

Formula 1: $H_T \leq 4.2 V_T$

Formula 2: $H_T + V_T \leq 24.75$ feet

Example 2:

$V_1 = V_T = 6$ FT

$H_1 = 3$ FT

$H_2 = 5$ FT

$H_R = H_1 + H_2 = 3 + 5 = 8$ FT

$H_o = .03$ (two 90° elbows - 90°) = .03 (180° - 90°) = 2.7 FT

$H_T = H_R + H_o = 8 + 2.7 = 10.7$ FT

$H_T + V_T = 10.7 + 6 = 16.7$ FT

Formula 1: $H_T \leq 4.2 V_T$
 $4.2 V_T = 4.2 \times 6 = 25.2$ FT

Formula 2: $H_T + V_T \leq 24.75$ FT
 $16.7 \leq 24.75$

Since both formulas are met, this vent configuration is acceptable.

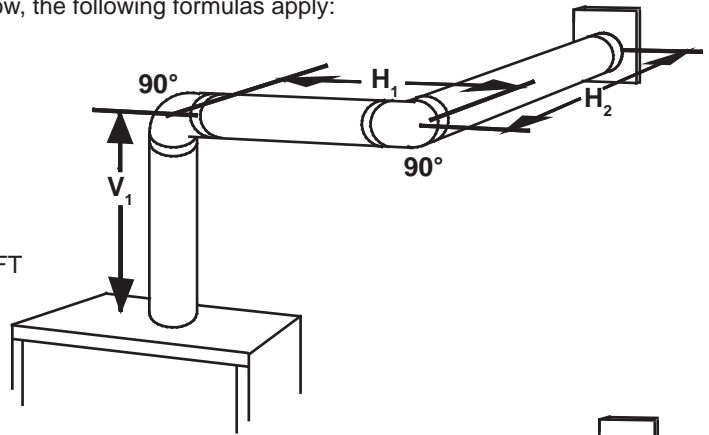

Example 3:

$V_1 = 4$ FT

$V_2 = 1.5$ FT

$V_T = V_1 + V_2 = 4 + 1.5 = 5.5$ FT

$H_1 = 2$ FT

$H_2 = 1$ FT

$H_3 = 1$ FT

$H_4 = 1.5$ FT

$H_R = H_1 + H_2 + H_3 + H_4 = 2 + 1 + 1 + 1.5 = 5.5$ FT

$H_o = .03$ (four 90° elbows - 90°) = .03 (360° - 90°) = 8.1 FT

$H_T = H_R + H_o = 5.5 + 8.1 = 13.6$ FT

$H_T + V_T = 13.6 + 5.5 = 19.1$ FT

Formula 1: $H_T \leq 4.2 V_T$
 $4.2 V_T = 4.2 \times 5.5 = 23.1$ FT

Formula 2: $H_T + V_T \leq 24.75$ FT
 $19.1 \leq 24.75$

Since both formulas are met, this vent configuration is acceptable.

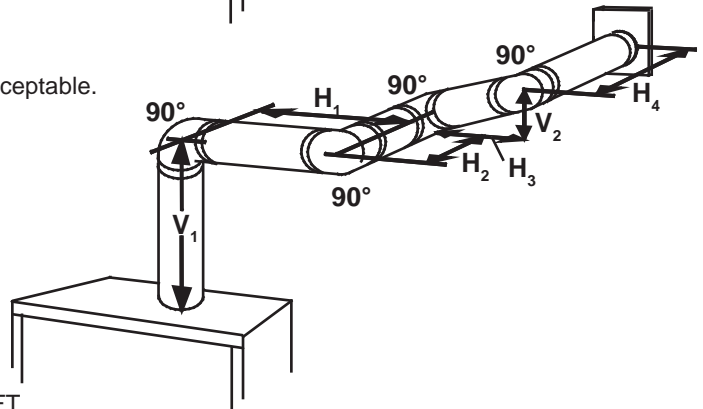

2.9 REAR EXIT HORIZONTAL TERMINATION

$$(H_T) \leq (V_T)$$

Simple venting configuration
(only two 90° elbows)

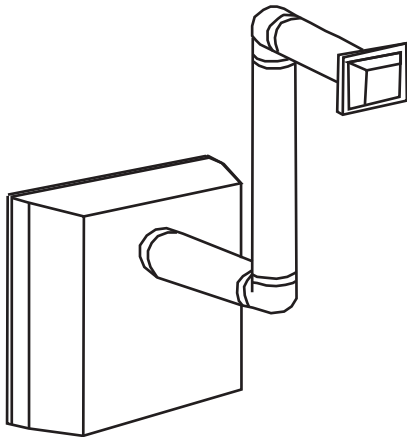

See graph to determine the required vertical rise V_T for the required horizontal run H_T .

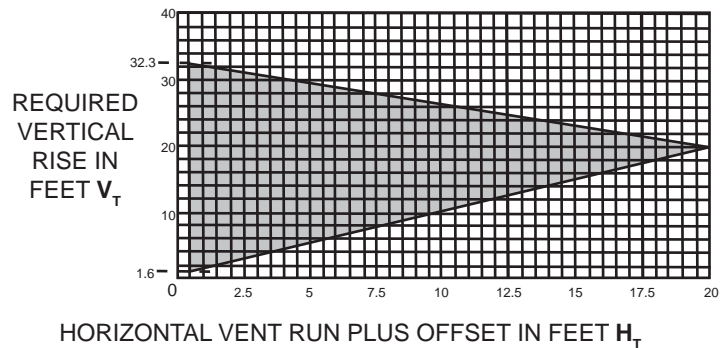

The shaded area within the lines represents acceptable values for H_T and V_T

For vent configurations requiring more than two 90° elbows, the following formulas apply:

Formula 1: $H_T \leq V_T$

Formula 2: $H_T + V_T \leq 35$ feet

Example 4:

$V_1 = 9$ FT

$V_2 = 6$ FT

$V_T = V_1 + V_2 = 9 + 6 = 15$ FT

$H_1 = 3$ FT

$H_2 = 2$ FT

$H_3 = 1.5$ FT

$H_R = H_1 + H_2 + H_3 = 3 + 2 + 1.5 = 6.5$ FT

$H_O = .03$ (four 90° elbows - 90°) = $.03 (360^\circ - 90^\circ) = 8.1$ FT

$H_T = H_R + H_O = 6.5 + 8.1 = 14.6$ FT

$H_T + V_T = 14.6 + 15 = 29.6$ FT

Formula 1: $H_T \leq V_T$
 $14.6 \leq 15$

Formula 2: $H_T + V_T \leq 35$ FT
 $29.6 \leq 35$

Since both formulas are met, this vent configuration is acceptable.

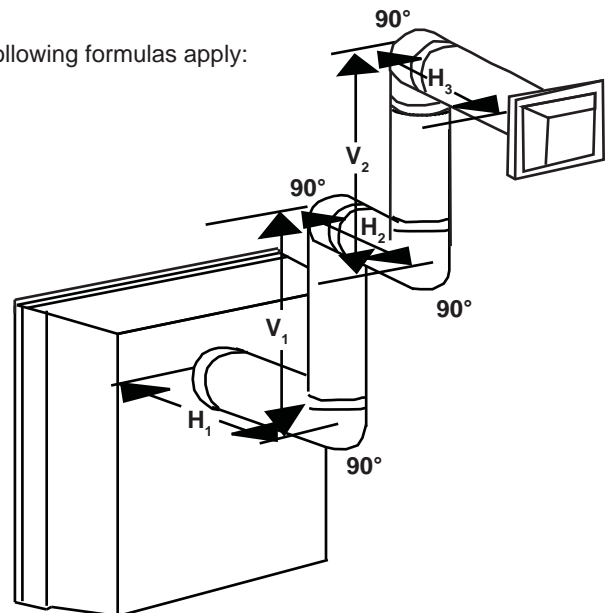

16.6_2

$$(H_T) > (V_T)$$

Simple venting configuration
(only two 90° elbows)

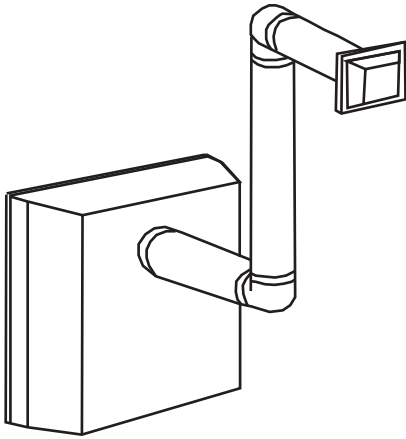

See graph to determine the required vertical rise V_T for the required horizontal run H_T .

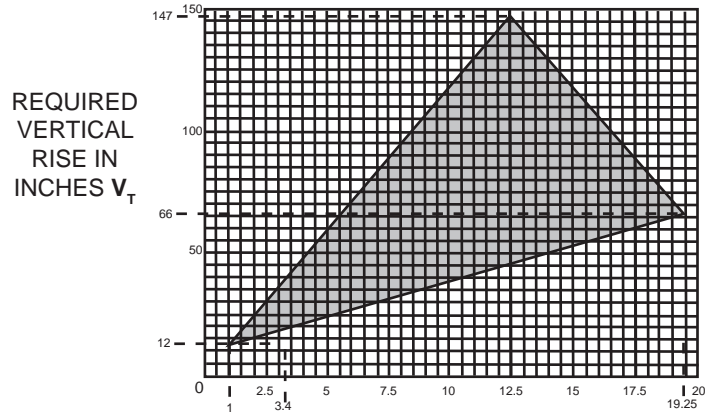

HORIZONTAL VENT RUN PLUS OFFSET IN FEET H_T

The shaded area within the lines represents acceptable values for H_T and H_T

For vent configurations requiring more than two 90° elbows, the following formulas apply:

Formula 1: $H_T \leq 3.5V_T$

Formula 2: $H_T + V_T \leq 24.75$ feet

Example 4:

$V_1 = 4$ FT

$V_2 = 1.5$ FT

$V_T = V_1 + V_2 = 4 + 1.5 = 5.5$ FT

$H_1 = 2$ FT

$H_2 = 1$ FT

$H_3 = 1$ FT

$H_4 = 1.5$ FT

$H_R = H_1 + H_2 + H_3 + H_4 = 2 + 1 + 1 + 1.5 = 5.5$ FT

$H_O = .03$ (four 90° elbows + one 45° elbow - 90°)

$= .03 (90 + 90 + 90 + 90 + 45 - 90) = 9.45$ FT

$H_T = H_R + H_O = 5.5 + 9.45 = 14.95$ FT

$H_T + V_T = 14.95 + 5.5 = 20.45$ FT

Formula 1: $H_T \leq 3.5V_T$
 $3.5V_T = 3.5 \times 5.5 = 19.25$ FT
 $14.95 \leq 19.25$

Formula 2: $H_T + V_T \leq 24.75$ FT
 $20.45 \leq 24.75$

Since both formulas are met, this vent configuration is acceptable.

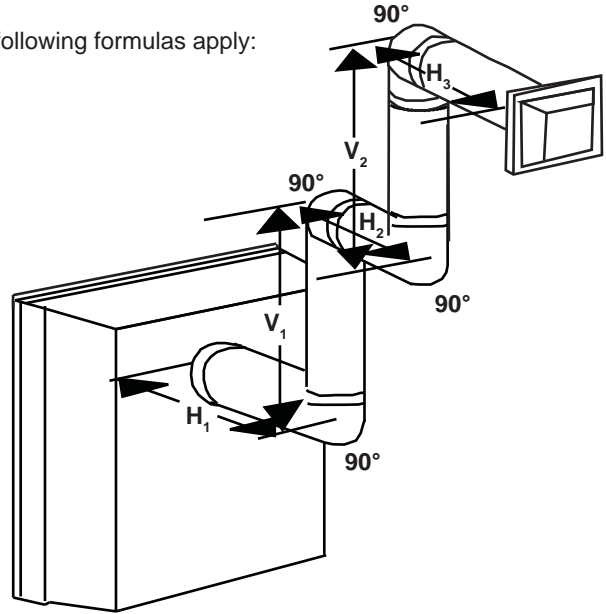

2.10 TOP OR REAR EXIT VERTICAL TERMINATION

$$(H_T) \leq (V_T)$$

Simple venting configurations.

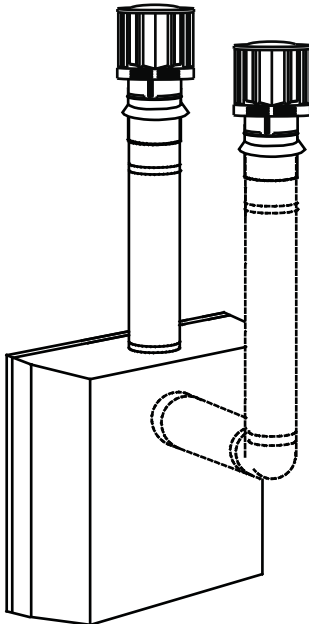

See graph to determine the required vertical rise V_T for the required horizontal run H_T .

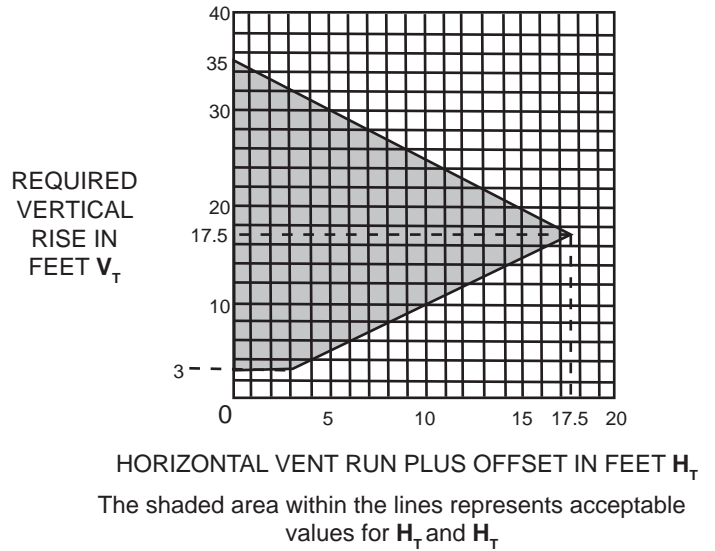

For vent configurations requiring one or more 90° elbows (top exit) or one 90° elbow (rear exit), the following formulas apply:

Formula 1: $H_T \leq V_T$

Formula 2: $H_T + V_T \leq 35$ feet

Example 6:

$V_1 = 3$ FT

$V_2 = 6$ FT

$V_3 = 8$ FT

$V_T = V_1 + V_2 + V_3 = 3 + 6 + 8 = 17$ FT

$H_1 = 2$ FT

$H_2 = 2.5$ FT

$H_R = H_1 + H_2 = 2 + 2.5 = 4.5$ FT

$H_O = .03$ (four 90° elbows - 90°)

$= .03$ (360° - 90°) = 8.1 FT

$H_T = H_R + H_O = 4.5 + 8.1 = 12.6$ FT

$H_T + V_T = 12.6 + 17 = 29.6$ FT

Formula 1: $H_T \leq 3.5 V_T$
 $12.6 \leq 17$

Formula 2: $H_T + V_T \leq 35$ FT
 $29.6 \leq 35$

Since both formulas are met, this vent configuration is acceptable.

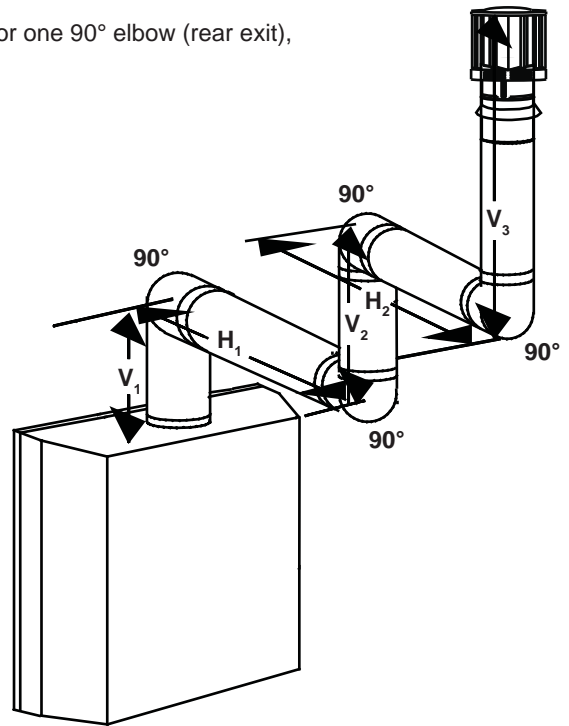

$(H_T) > (V_T)$

Simple venting configurations.

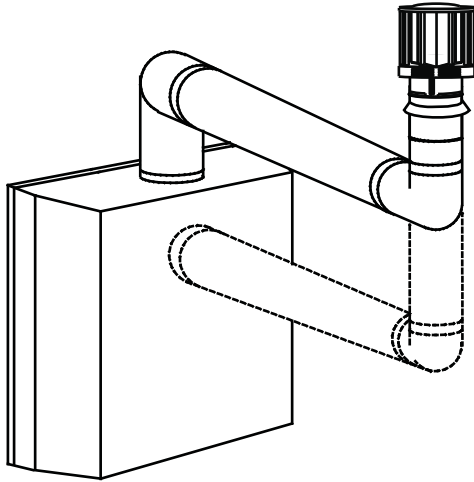

See graph to determine the required vertical rise V_T for the required horizontal run H_T .

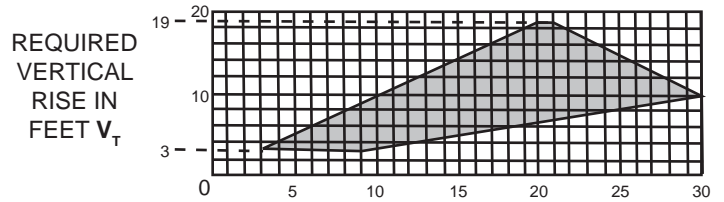

HORIZONTAL VENT RUN PLUS OFFSET IN FEET H_T

The shaded area within the lines represents acceptable values for H_T and V_T

For vent configurations requiring more than one 90° elbows (top exit) or one 90° elbow (rear exit), the following formulas apply:

Formula 1: $H_T \leq 3 V_T$

Formula 2: $H_T + V_T \leq 35$ feet

Example 7:

$V_1 = 2$ FT

$V_2 = 1$ FT

$V_3 = 1.5$ FT

$V_T = V_1 + V_2 + V_3 = 2 + 1 + 1.5 = 4.5$ FT

$H_1 = 6$ FT

$H_2 = 2$ FT

$H_R = H_1 + H_2 = 6 + 2 = 8$ FT

$H_O = .03$ (four 90° elbows - 90°)

$= .03$ (360° - 90°) = 8.1 FT

$H_T = H_R + H_O = 8 + 8.1 = 16.1$ FT

$H_T + V_T = 16.1 + 4.5 = 20.6$ FT

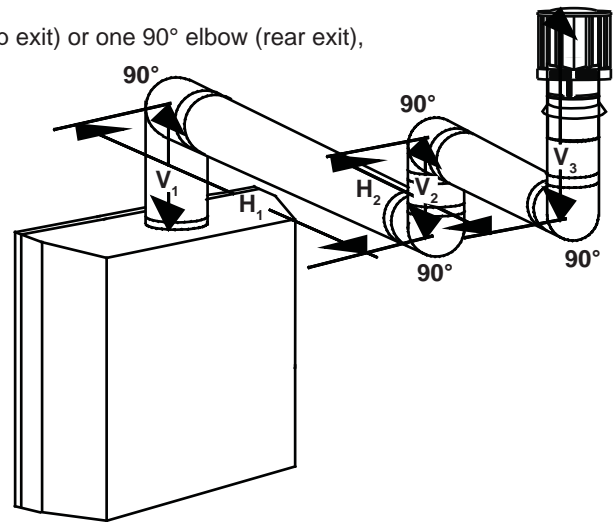

Formula 1: $H_T \leq 3.5 V_T$
 $3.5 V_T = 3 \times 4.5 = 13.5$ FT
 $16.1 \leq 13.5$

Since this formula is not met, this vent configuration is **unacceptable**.

Formula 2: $H_T + V_T \leq 35$ FT
 $20.6 \leq 35$

Since only formula 2 is met, this vent configuration is unacceptable and a new fireplace location or vent configuration will need to be established to satisfy both formulas.

Example 8:

$$V_1 = 1.5 \text{ FT}$$

$$V_2 = 5 \text{ FT}$$

$$V_T = V_1 + V_2 = 1.5 + 1 + 5 = 6.5 \text{ FT}$$

$$H_1 = 1 \text{ FT}$$

$$H_2 = 1 \text{ FT}$$

$$H_3 = 10.75 \text{ FT}$$

$$H_R = H_1 + H_2 + H_3 = 1 + 1 + 10.75 = 12.75 \text{ FT}$$

$$H_O = .03 \text{ (four } 90^\circ \text{ elbows + one } 45^\circ \text{ elbow - } 90^\circ)$$

$$= .03 (360^\circ + 45^\circ - 90^\circ) = 6.75 \text{ FT}$$

$$H_T = H_R + H_O = 12.75 + 6.75 = 19.5 \text{ FT}$$

$$H_T + V_T = 19.5 + 6.5 = 26 \text{ FT}$$

Formula 1:

$$H_T \leq 3 V_T$$

$$3 V_T = 3 \times 6.5 = 19.5 \text{ FT}$$

$$19.5 = 19.5$$

Formula 2:

$$H_T + V_T \leq 35 \text{ FT}$$

$$26 \leq 35$$

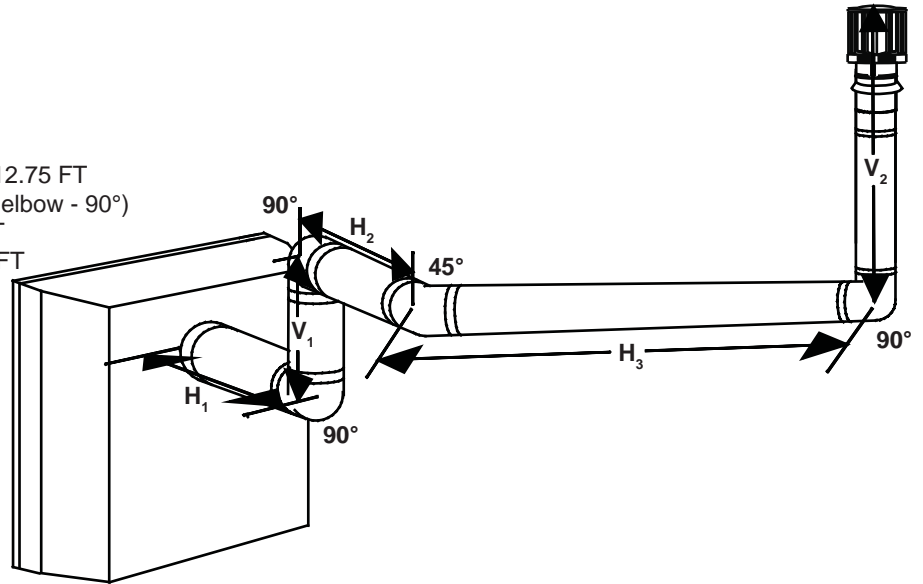

Since both formulas are met, this vent configuration is acceptable.

18.4_3

2.11 REAR VENT CONVERSION

In order to convert the venting configuration from a **top exit** to a **rear exit**, remove components as illustrated:
When reinstalling in the alternate position: Check gaskets for tears, replace if necessary to ensure a proper seal.

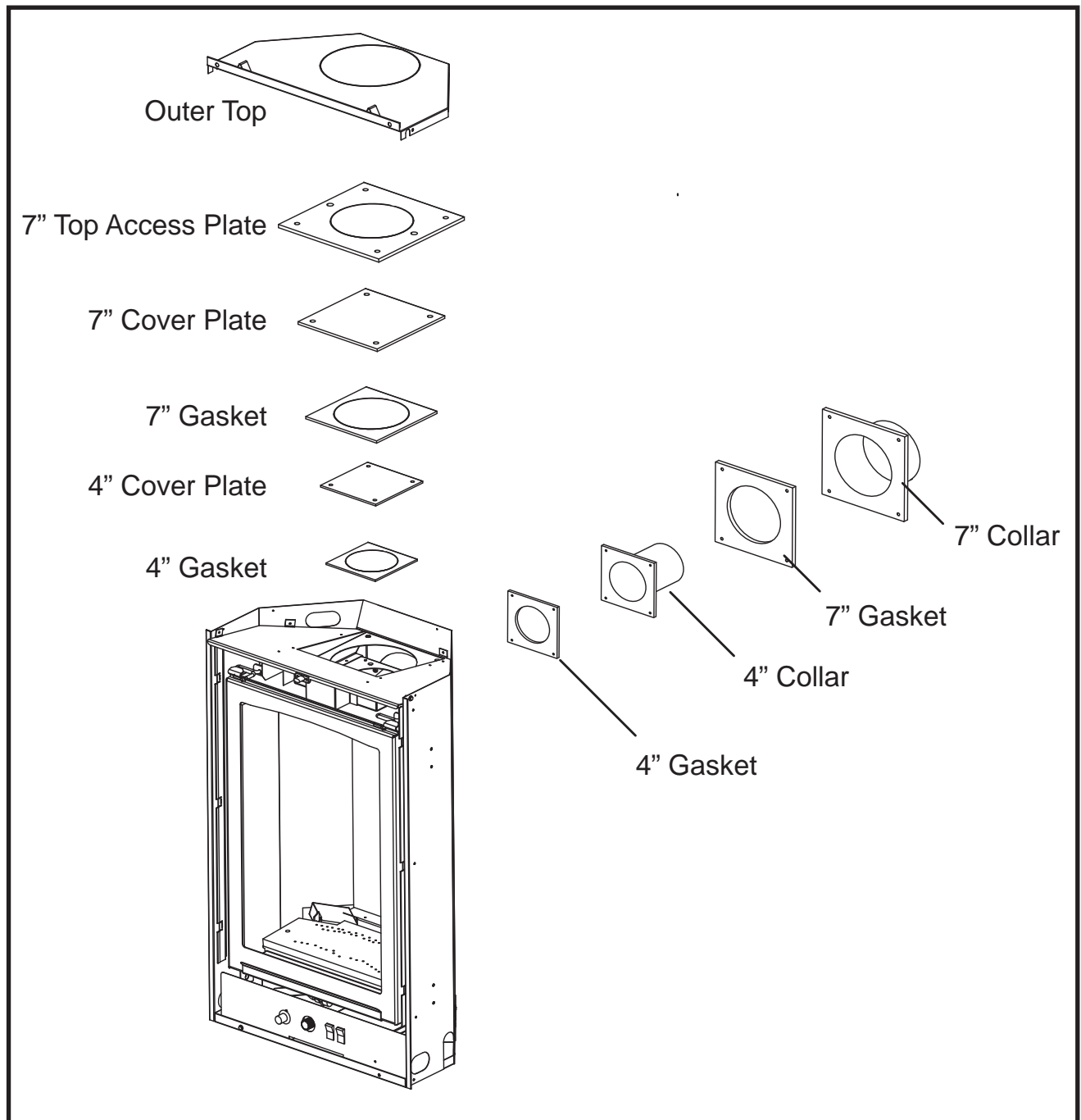

3.0 INSTALLATION

 WARNING
FOLLOW THE VENTING INSTRUCTIONS EXACTLY.
ALL INNER EXHAUST AND OUTER INTAKE VENT PIPE JOINTS MAY BE SEALED USING EITHER RED RTV HIGH TEMP SILICONE SEALANT W573-0002 (NOT SUPPLIED) OR BLACK HIGH TEMP MILL PAC W573-0007 (NOT SUPPLIED) WITH THE EXCEPTION OF THE APPLIANCE EXHAUST FLUE COLLAR WHICH MUST BE SEALED USING MILL PAC.
IF USING PIPE CLAMPS TO CONNECT VENT COMPONENTS, 3 SCREWS MUST ALSO BE USED TO ENSURE THE CONNECTION CANNOT SLIP OFF.
DO NOT CLAMP THE FLEXIBLE VENT PIPE.
RISK OF FIRE, EXPLOSION OR ASPHYXIATION. IMPROPER SUPPORT OF THE ENTIRE VENTING SYSTEM MAY ALLOW VENT TO SAG AND SEPARATE. USE VENT RUNS SUPPORT AND CONNECT VENT SECTIONS PER INSTALLATION INSTRUCTIONS.
RISK OF FIRE, DO NOT ALLOW LOOSE MATERIALS OR INSULATION TO TOUCH THE VENT PIPE. REMOVE INSULATION TO ALLOW FOR THE INSTALLATION OF THE ATTIC SHIELD AND TO MAINTAIN CLEARANCES TO COMBUSTIBLES.

3.1 WALL AND CEILING PROTECTION

 WARNING
DO NOT FILL THE SPACE BETWEEN THE VENT PIPE AND ENCLOSURE WITH ANY TYPE OF MATERIAL. DO NOT PACK INSULATION OR COMBUSTIBLES BETWEEN CEILING FIRESTOPS. ALWAYS MAINTAIN SPECIFIED CLEARANCES AROUND VENTING AND FIRESTOP SYSTEMS. INSTALL WALL SHIELDS AND FIRESTOPS AS SPECIFIED. FAILURE TO KEEP INSULATION OR OTHER MATERIALS AWAY FROM VENT PIPE MAY CAUSE FIRE.

For clearances to combustible materials from the vent pipe, see "FRAMING" section.

For optimum performance it is recommended that horizontal runs have a minimum 1" per rise per foot when using Simpson Dura-Vent, Selkirk Direct Temp, American Metal Amerivent, or Wolf Steel rigid or flexible vent components.

3.1.1 HORIZONTAL INSTALLATION

! WARNING

THE FIRESTOP ASSEMBLY MUST BE INSTALLED WITH THE VENT SHIELD TO THE TOP.

TERMINALS MUST NOT BE RECESSED INTO A WALL OR SIDING MORE THAN THE DEPTH OF THE RETURN FLANGE OF THE MOUNTING PLATE.

This application occurs when venting through an exterior wall. Having determined the correct height for the air terminal location, cut and frame a hole in the exterior wall as illustrated to accommodate the firestop assembly. Dry fit the firestop assembly before proceeding to ensure the brackets on the rear surface fit to the inside surface of the horizontal framing.

The length of the vent shield may be cut shorter for combustible walls that are less than 8 1/2" thick but the vent shield must extend the full depth of the combustible wall.

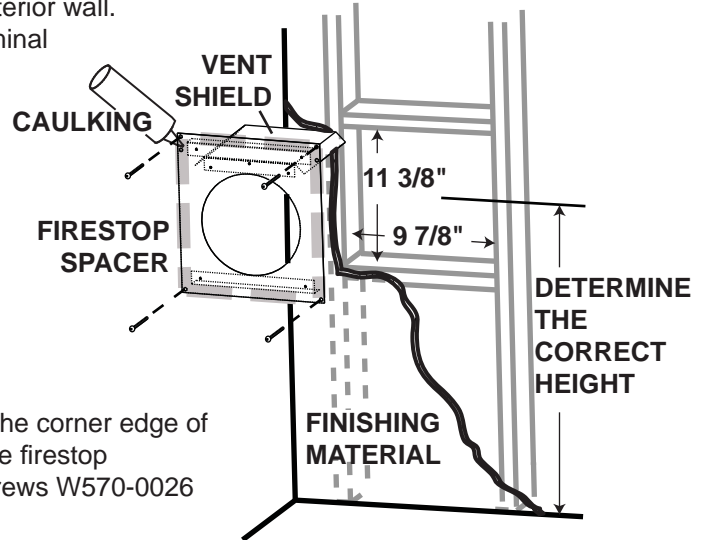

- A. Apply a bead of caulking (not supplied) around the corner edge of the inside surface of the firestop assembly, fit the firestop assembly to the hole and secure using the 4 screws W570-0026 (supplied in your manual baggie).
- B. Once the vent pipe is installed in its final position, apply high temperature sealant W573-0007 (not supplied) between the pipe and the firestop.

20.2

3.1.2 VERTICAL INSTALLATION

This application occurs when venting through a roof. Installation kits for various roof pitches are available from your authorized dealer / distributor. See accessories to order specific kits required.

- A. Determine the air terminal location, cut and frame a square opening as illustrated in the ceiling and the roof to provide the minimum 1" clearance between the vent pipe and any combustible material. Try to center the vent pipe location midway between two joists to prevent having to cut them. Use a plumb bob to line up the center of the openings. A vent pipe shield will prevent any materials such as insulation, from filling up the 1" air space around the pipe. Nail headers between the joist for extra support.
- B. Apply a bead of caulking (not supplied) to the framework or to the Wolf Steel vent pipe shield plate or equivalent (in the case of a finished ceiling), and secure over the opening in the ceiling. A firestop must be placed on the bottom of each framed opening in a roof or ceiling that the venting system passes through. Apply a bead of caulking all around and place a firestop spacer over the vent shield to restrict cold air from being drawn into the room or around the fireplace. Ensure that both spacer and shield maintain the required clearance to combustibles. Once the vent pipe is installed in its final position, apply sealant between the pipe and the firestop assembly.
- C. In the attic, slide the vent pipe collar down to cover up the open end of the shield and tighten. This will prevent any materials, such as insulation, from filling up the 1" air space around the pipe.

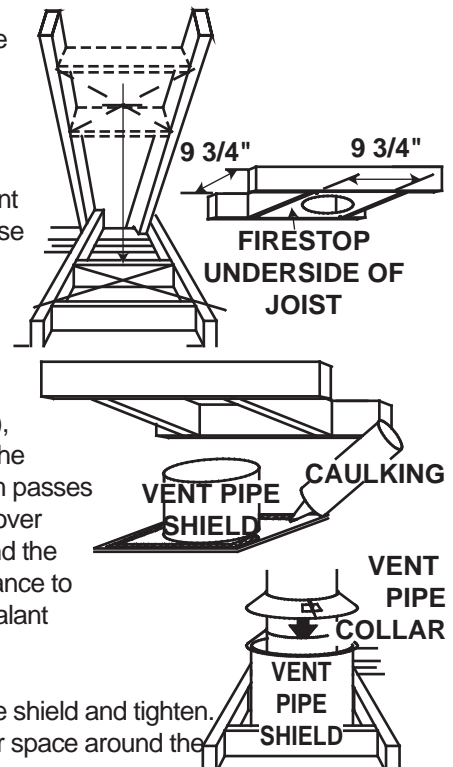

21.1

3.2 USING FLEXIBLE VENT COMPONENTS

! WARNING

DO NOT ALLOW THE INNER FLEX PIPE TO BUNCH UP ON HORIZONTAL OR VERTICAL RUNS AND ELBOWS. KEEP IT PULLED TIGHT.

SPACERS ARE ATTACHED TO THE INNER FLEX PIPE AT PREDETERMINED INTERVALS TO MAINTAIN AN EVEN AIR GAP TO THE OUTER FLEX PIPE. THIS GAP IS REQUIRED FOR SAFE OPERATION. A SPACER IS REQUIRED AT THE START, MIDDLE AND END OF EACH ELBOW TO ENSURE THIS GAP IS MAINTAINED. THESE SPACERS MUST NOT BE REMOVED.

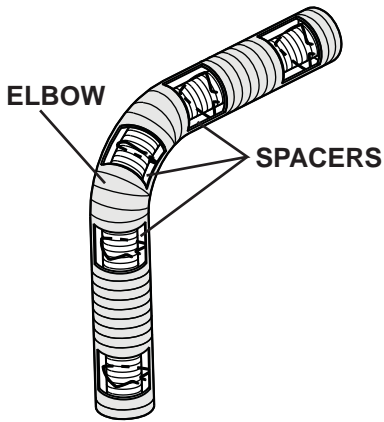

For safe and proper operation of the appliance, follow the venting instructions exactly.

All inner flex pipe and outer flex pipe joints may be sealed using high temperature sealant W573-0002 (not supplied) or the high temperature sealant W573-0007 Mill Pac (not supplied). However, the high temperature sealant W573-0007 Mill Pac (not supplied) must be used on the joint connecting the inner flex pipe and the exhaust flue collar.

Use only approved flexible vent pipe kits marked:

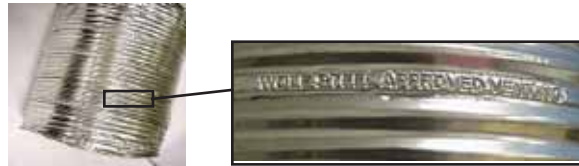

“Wolf Steel Approved Venting” as identified by the stamp only on the outer flex pipe.

22.1

3.2.1 HORIZONTAL AIR TERMINAL INSTALLATION

A. Stretch the inner flex pipe to the required length taking into account the additional length needed for the finished wall surface. Slip the vent pipe a minimum of 2” over the inner sleeve of the air terminal and secure with 3 #8 screws. Apply a heavy bead of the high temperature sealant W573-0007 Mill Pac (not supplied).

B. Using the outer flex pipe, slide over the outer combustion air sleeve of the air terminal and secure with 3 #8 screws. Seal using high temperature sealant W573-0002 (not supplied).

C. Insert the vent pipes through the firestop maintaining the required clearance to combustibles. Holding the air terminal (lettering in an upright, readable position), secure to the exterior wall and make weather tight by sealing with caulking (not supplied).

D. If more vent pipe needs to be used to reach the fireplace, couple them together as illustrated. The vent system must be supported approximately every 3 feet for both vertical and horizontal runs. Use noncombustible strapping to maintain the minimum clearance to combustibles.

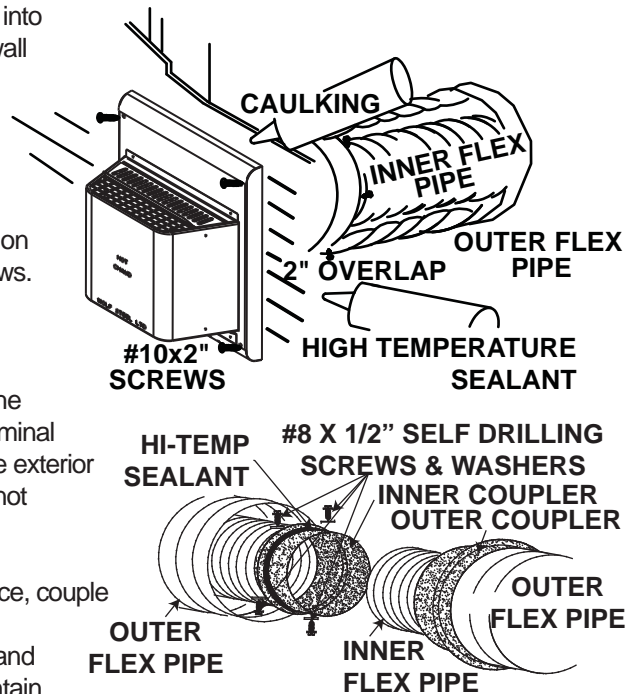

The air terminal mounting plate may be recessed into the exterior wall or siding no greater than the depth of its return flange.

23.1

3.2.2 VERTICAL AIR TERMINAL INSTALLATION

! WARNING

MAINTAIN A MINIMUM 2" SPACE BETWEEN THE AIR INLET BASE AND THE STORM COLLAR.

A. Fasten the roof support to the roof using the screws provided. The roof support is optional. In this case the venting is to be adequately supported using either an alternate method suitable to the authority having jurisdiction or the optional roof support.

B. Stretch the inner flex pipe to the required length. Slip the inner flex pipe a minimum of 2" over the inner pipe of the air terminal connector and secure with 3 #8 screws. Seal using a heavy bead of high temperature sealant W573-0007 (not supplied).

C. Repeat using the outer flex pipe, using a heavy bead of high temperature sealant W573-0002 (not supplied).

D. Thread the air terminal connector / vent pipe assembly down through the roof. The air terminal must be positioned vertically and plumb. Attach the air terminal connector to the roof support, ensuring that the top of the air terminal is 16" above the highest point that it penetrates the roof.

E. Remove nails from the shingles, above and to the sides of the air terminal connector. Place the flashing over the air terminal connector leaving a min. 3/4" of the air terminal connector showing above the top of the flashing. Slide the flashing underneath the sides and upper edge of the shingles. Ensure that the air terminal connector is properly centred within the flashing, giving a 3/4" margin all around. Fasten to the roof. Do not nail through the lower portion of the flashing. Make weather-tight by sealing with caulking. Where possible, cover the sides and top edges of the flashing with roofing material.

F. Aligning the seams of the terminal and air terminal connector, place the terminal over the air terminal connector making sure the vent pipe goes into the hole in the terminal. Secure with the three screws provided.

G. Apply a heavy bead of weatherproof caulking 2" above the flashing. Install the storm collar around the air terminal and slide down to the caulking. Tighten to ensure that a weather-tight seal between the air terminal and the collar is achieved.

H. If more vent pipe needs to be used to reach the appliance see "HORIZONTAL AIR TERMINAL INSTALLATION" section.

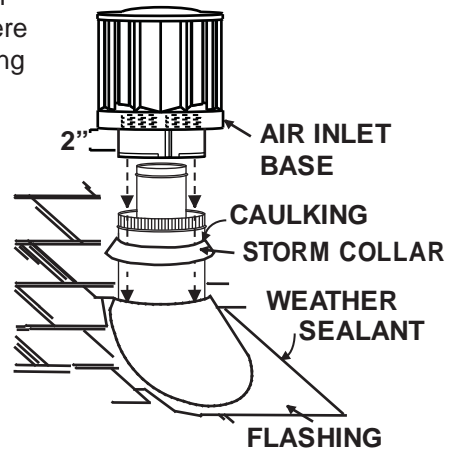
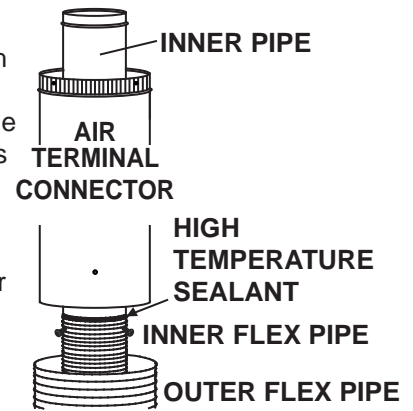
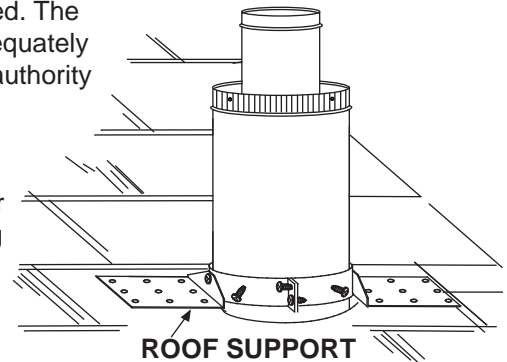

24.1

3.2.3 APPLIANCE VENT CONNECTION

A. Install the inner flex pipe to the appliance. Secure with 3 screws and flat washers. Seal the joint and screw holes using the high temperature sealant W573-0007 (not supplied).

B. Install the outer flex pipe to the appliance. Attach and seal the joints using the high temperature sealant W573-0002 (not supplied).

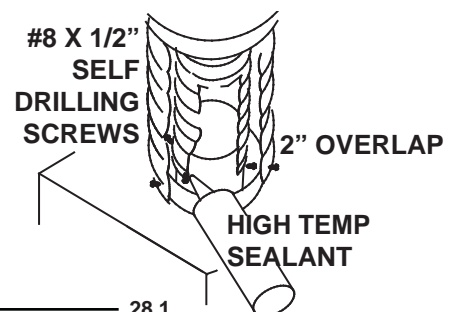

28.1

3.3 USING RIGID VENT COMPONENTS

The vent system must be supported approximately every 3 feet for both vertical and horizontal runs. Use Wolf Steel Ltd. support ring assembly or equivalent noncombustible strapping to maintain the minimum clearance to combustibles for both vertical and horizontal runs.

All inner exhaust and outer intake vent pipe joints may be sealed using either red high temperature silicone sealant W573-0002 (not supplied) or black high temperature sealant W573-0007 Mill Pac (not supplied) with the exception of the appliance exhaust flue collar which must be sealed using Mill Pac.

25.1

3.3.1 HORIZONTAL AIR TERMINAL INSTALLATION

! WARNING

RISK OF FIRE, DO NOT ALLOW LOOSE MATERIALS OR INSULATION TO TOUCH THE VENT PIPE. REMOVE INSULATION TO ALLOW FOR THE INSTALLATION OF THE ATTIC SHIELD AND TO MAINTAIN CLEARANCES TO COMBUSTIBLES.

- A. Move the appliance into position. Measure the vent length required between terminal and appliance taking into account the additional length needed for the finished wall surface and any 1¼" overlaps between venting components.

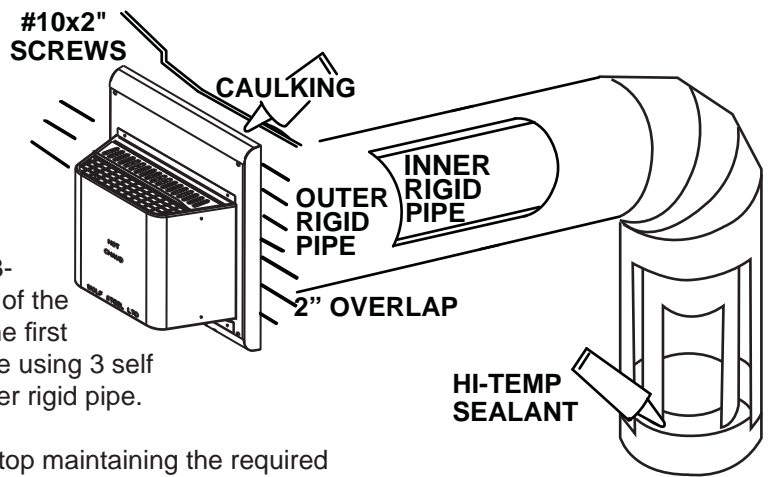

- B. Apply high temperature sealant W573-0007 (not supplied) to the outer edge of the inner collar of the appliance. Attach the first inner rigid pipe component and secure using 3 self tapping screws. Repeat using the outer rigid pipe.

- C. Insert the vent pipes through the firestop maintaining the required clearance to combustibles. Holding the air terminal (lettering in an upright, readable position), secure to the exterior wall and make weather tight by sealing with caulking (not supplied).

The air terminal mounting plate may be recessed into the exterior wall or siding no greater than the depth of the return flange.

26.3

3.3.2 EXTENDED HORIZONTAL AND CORNER AIR TERMINAL INSTALLATION

- A. Follow the instructions for "HORIZONTAL AIR TERMINAL INSTALLATIONS" section.
- B. Continue adding components alternating inner rigid pipe and outer rigid pipe. Ensure that all inner rigid pipe and elbows have sufficient vent spacers attached and each component is sealed and securely fastened to the one prior. Attach the inner telescopic sleeve to the vent run. Repeat using the outer telescopic sleeve. Seal and secure as before. To facilitate completion, attach inner and outer couplers to the air terminal.
- C. Install the air terminal. See "HORIZONTAL AIR TERMINAL INSTALLATION" section.

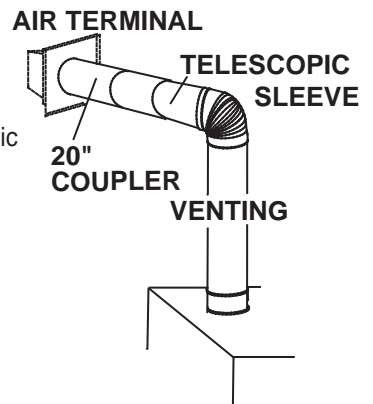

48.1

3.3.3 VERTICAL AIR TERMINAL INSTALLATION

NOTE: Before attaching elbows to the collars on the back of the appliance, 1 1/2" will need to be trimmed off the 4" collar.

REAR VENT APPLICATION: Attach 4" and 7" elbows to the appliance. Secure with 3 screws and seal the joints and screw heads using high temperature sealant. Proceed to step A below.

TOP VENT APPLICATION:

- A. Move the appliance into position.
- B. Fasten the roof support to the roof using the screws provided. The roof support is optional. In this case the venting is to be adequately supported using either an alternate method suitable to the authority having jurisdiction or the optional roof support.
- C. Apply high temperature sealant W573-0007 (not supplied) to the outer edge of the inner sleeve of the air terminal. Slip the inner coupler a minimum of 2" over the sleeve and secure using 3 screws.
- D. Apply high temperature sealant W573-0002 (not supplied) to the outer edge of the of the outside sleeve of the air terminal connector. Slip the outer coupler over the sleeve and secure as before. Trim the outer coupler even with the inner coupler end.
- E. Thread the air terminal connector / vent pipe assembly down through the roof support and attach, ensuring that a minimum 16" of air terminal connector will penetrate the roof when fastened. If the attic space is tight, we recommend threading the Wolf Steel vent pipe collar or equivalent loosely onto the air terminal connector / vent pipe assembly as it is passed through the attic. The air terminal connector must be positioned vertically and plumb.
- F. Remove nails from the shingles, above and to the sides of the air terminal connector. Place the flashing over the air terminal connector and slide it underneath the sides and upper edge of the shingles. Ensure that the air terminal connector is properly centered within the flashing, giving a 3/4" margin all around. Fasten to the roof. **Do NOT nail through the lower portion of the flashing.** Make weather-tight by sealing with caulking. Where possible, cover the sides and top edges of the flashing with roofing material.
- G. Apply a heavy bead of waterproof caulking 2" above the flashing. Install the storm collar around the air terminal and slide down to the caulking. Tighten to ensure that a weather-tight seal between the air terminal connector and the collar is achieved.
- H. Continue adding rigid venting sections, sealing and securing as above. Attach the inner collapsed telescopic sleeve to the last section of rigid piping. Secure with screws and seal. Repeat using the outer telescopic sleeve.

REAR VENT APPLICATION:

- I. Run a bead of high temperature sealant W573-0007 (not supplied) around the outside of the inner elbow. Pull the telescopic sleeve a minimum of 2" onto the elbow. Secure with 3 screws. Repeat with the outer telescopic sleeve.

TOP VENT APPLICATION:

- J. Run a bead of high temperature sealant W573-0007 (not supplied) around the outside of the inner collar on the appliance. Pull the telescopic sleeve a minimum of 2" onto the collar. Secure with 3 screws. Repeat with the outer telescopic sleeve.
- K. In the attic, slide the vent pipe collar down to cover up the open end of the shield and tighten. This will prevent any materials, such as insulation, from filling up the 1" air space around the pipe

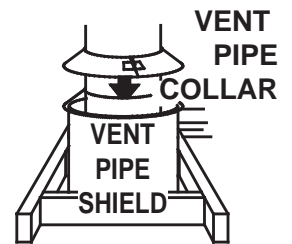
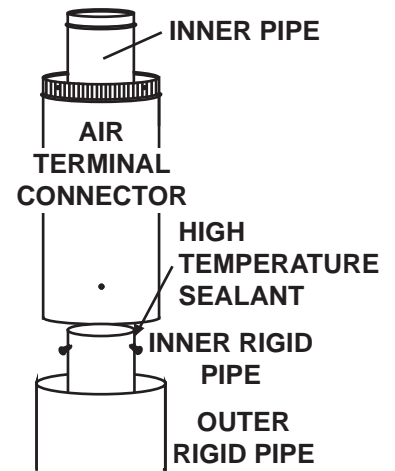

3.3.4 RESTRICTING VERTICAL VENTS

Vertical terminations running longer than 15 feet may display a very active flame. If this appearance is not desirable, the vent exit must be restricted to reduce the velocity of the exhaust gases, thus slowing down the flame pattern and creating a more traditional gentle appearance. Remove the baffle plate from the rear wall of the firebox, exposing the flue gas outlet opening. Superimpose this outlet hole with the smaller hole on the kit restrictor plate. Secure with the two screws provided and replace the baffle plate.

- A. Remove the front and the door from the appliance.
- B. Remove the screws securing the baffle plate.
NOTE: The baffle rests on two screws that are attached to the back of the firebox.
- C. Using the screws supplied, attach the restrictor plate as illustrated.
- D. Replace the baffle.

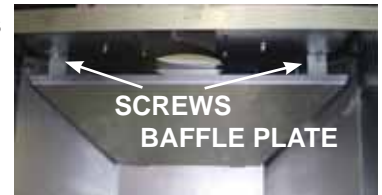

3.4 MOBILE HOME INSTALLATION

This appliance is certified to be installed as an OEM (Original Equipment Manufacturer) installation in a manufactured home or mobile home and must be installed in accordance with the manufacturer's instructions and the Manufactured Home Construction and Safety Standard, Title 24 CFR, Part 3280, in the United States or the Mobile Home Standard, CAN/CSA Z240 MH Series, in Canada. This appliance is only for use with the type(s) of gas indicated on the rating plate. A conversion kit is supplied with the mobile home appliance.

This Mobile/Manufactured Home Listed appliance comes factory equipped with a means to secure the unit. Built in appliances are equipped with 1/4" diameter holes located in the front left and right corners of the base. Use #10 hex head screws, inserted through the holes in the base to secure. For free standing products contact your local authorized dealer / distributor for the appropriate securing kit. For mobile home installations, the appliance must be fastened in place. It is recommended that the appliance be secured in all installations. Always turn off the pilot and the fuel supply at the source, prior to moving the mobile home. After moving the mobile home and prior to lighting the appliance, ensure that the logs are positioned correctly.

This appliance is certified to be installed in an aftermarket permanently located, manufactured (mobile) home, where not prohibited by local codes.
This appliance is only for use with the type of gas indicated on the rating plate. This appliance is not convertible for use with other gases, unless a certified kit is used.

Conversion Kits

This appliance is field convertible between Natural Gas (NG) and Propane (LP).
To convert from one gas to another consult your Authorized dealer/distributor.

3.5 GAS INSTALLATION

! WARNING
RISK OF FIRE, EXPLOSION OR ASPHYXIATION. ENSURE THERE ARE NO IGNITION SOURCES SUCH AS SPARKS OR OPEN FLAMES.
SUPPORT GAS CONTROL WHEN ATTACHING GAS SUPPLY PIPE TO PREVENT DAMAGING GAS LINE.
ALWAYS LIGHT THE PILOT WHETHER FOR THE FIRST TIME OR IF THE GAS SUPPLY HAS RUN OUT WITH THE GLASS DOOR OPENED OR REMOVED. PURGING OF THE GAS SUPPLY LINE SHOULD BE PERFORMED BY A QUALIFIED SERVICE TECHNICIAN. ASSURE THAT A CONTINUOUS GAS FLOW IS AT THE BURNER BEFORE CLOSING THE DOOR. ENSURE ADEQUATE VENTILATION. FOR GAS AND ELECTRICAL LOCATIONS, SEE "DIMENSION" SECTION.
ALL GAS CONNECTIONS MUST BE CONTAINED WITHIN THE APPLIANCE WHEN COMPLETE.
HIGH PRESSURE WILL DAMAGE VALVE. DISCONNECT GAS SUPPLY PIPING BEFORE TESTING GAS LINE AT TEST PRESSURES ABOVE 1/2 PSIG.
VALVE SETTINGS HAVE BEEN FACTORY SET, DO NOT CHANGE.

Proceed once the vent installation is complete. Installation and servicing to be done by a qualified installer
Do not use open flame.

- 3.5.1** Move the appliance into position and secure.
- 3.5.2** If equipped with a flex connector the appliance is designed to accept a 1/2" gas supply. Without the connector it is designed to accept a 3/8" gas supply. The appliance is equipped with a manual shut off valve to turn off the gas supply to the appliance.
- 3.5.3** Connect the gas supply in accordance to local codes. In the absence of local codes, install to the current CAN/CSA-B149.1 Installation Code in Canada or to the current National Fuel Gas Code, ANSI Z223.1 / NFPA 54 in the United States.
- 3.5.4** When flexing any gas line, support the gas valve so that the lines are not bent or kinked.
- 3.5.5** Check for gas leaks by brushing on a soap and water solution.

30.1

3.6 OPTIONAL WALL SWITCH

! WARNING
DO NOT CONNECT EITHER THE WALL SWITCH, THERMOSTAT OR GAS VALVE DIRECTLY TO 110 VOLT ELECTRICITY.

The main burner and Night Light™ switch is located behind lower access panel. For ease of accessibility, optional remote wall switches may be installed in a convenient location for both burner and light operation.

The recommended maximum lead length depends on wire size:

WIRE SIZE	MAX. LENGTH
14 gauge	100 feet
16 gauge	60 feet
18 gauge	40 feet

Route 2-strand (solid core) wire through the electrical hole located at the bottom left side of the unit. Connect the wires from the main burner wall switch to the two

corresponding spade connectors on the back of the on/off switch for the burner located behind the lower access panel. Repeat connecting the wires to the Night Light™ on/off switch for remote operation.

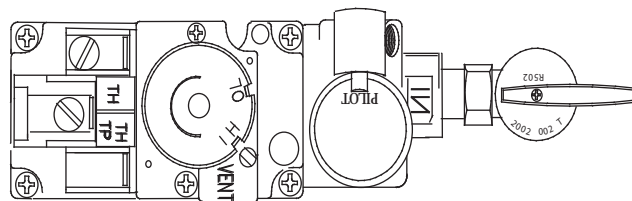

50.4

4.0 FRAMING

WARNING

IN ORDER TO AVOID THE POSSIBILITY OF EXPOSED INSULATION OR VAPOUR BARRIER COMING IN CONTACT WITH THE APPLIANCE BODY, IT IS RECOMMENDED THAT THE WALLS OF THE APPLIANCE ENCLOSURE BE “FINISHED” (IE: DRYWALL / SHEETROCK), AS YOU WOULD FINISH ANY OTHER OUTSIDE WALL OF A HOME. THIS WILL ENSURE THAT CLEARANCE TO COMBUSTIBLES IS MAINTAINED WITHIN THE CAVITY.

DO NOT NOTCH THE FRAMING AROUND THE APPLIANCE STAND-OFFS. FAILURE TO MAINTAIN AIR SPACE CLEARANCE MAY CAUSE OVER HEATING AND FIRE. PREVENT CONTACT WITH SAGGING OR LOOSE INSULATION OR FRAMING AND OTHER COMBUSTIBLE MATERIALS. BLOCK OPENING INTO THE CHASE TO PREVENT ENTRY OF BLOWN-IN INSULATION. MAKE SURE INSULATION AND OTHER MATERIALS ARE SECURED.

It is best to frame your appliance after it is positioned and the vent system is installed. Frame to local building codes.

To install the appliance face flush with the finished wall, position the framework to accommodate the thickness of the finished wall.

It is not necessary to install a hearth extension with this appliance system.

When roughing in the appliance, raise the appliance to accommodate for the thickness of the finished floor materials, i.e. tile, carpeting, hard wood, which if not planned for will interfere with the opening of the lower access door and the installation of many decorative flashing accessories.

4.1 MINIMUM CLEARANCE TO COMBUSTIBLES

WARNING

MINIMUM CLEARANCE TO COMBUSTIBLES MUST BE MAINTAINED OR A SERIOUS FIRE HAZARD COULD RESULT.

WHEN CONSTRUCTING THE ENCLOSURE ALLOW FOR FINISHING MATERIAL THICKNESS TO MAINTAIN CLEARANCES. FRAMING OR FINISHING MATERIAL CLOSER THAN THE MINIMUMS LISTED MUST BE CONSTRUCTED ENTIRELY OF NON-COMBUSTIBLE MATERIALS. MATERIALS CONSISTING ENTIRELY OF STEEL, IRON, BRICK, TILE, CONCRETE, SLATE, GLASS OR PLASTERS, OR ANY COMBINATION THEREOF ARE SUITABLE. MATERIALS THAT ARE REPORTED AS PASSING ASTM E 136, STANDARD TEST METHOD FOR BEHAVIOUR OF MATERIALS IN A VERTICAL TUBE FURNACE AT 750°C AND UL763 SHALL BE CONSIDERED NON-COMBUSTIBLE MATERIALS.

NEVER OBSTRUCT THE FRONT OPENING OF THE APPLIANCE.

4.1.1 REAR VENT

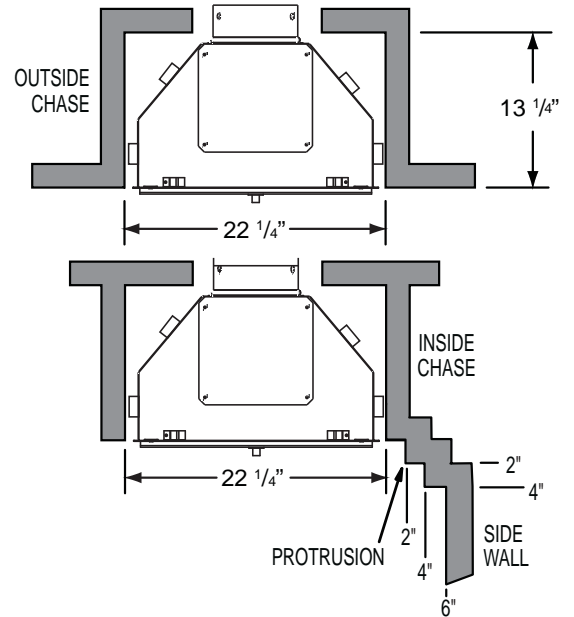
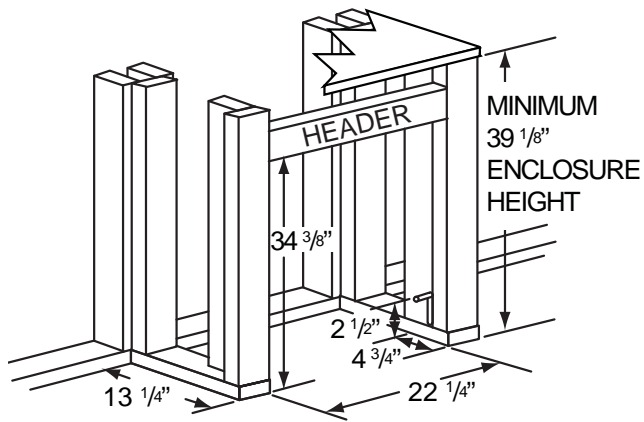

4.1.2 TOP VENT

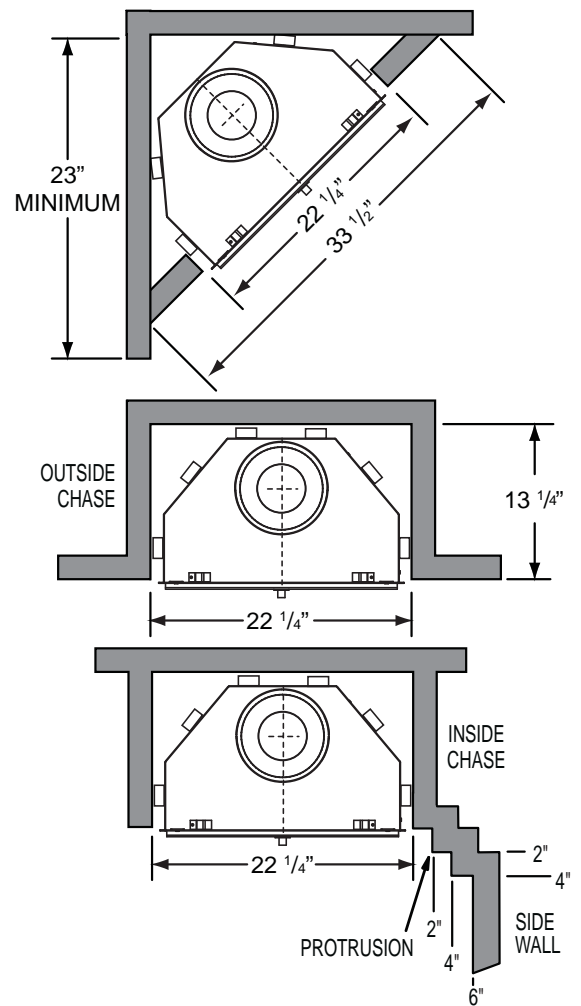
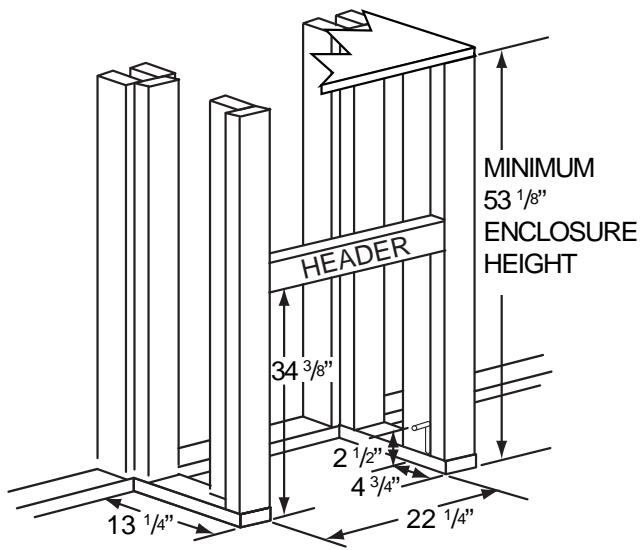

4.2 MINIMUM CLEARANCE TO COMBUSTIBLE ENCLOSURES

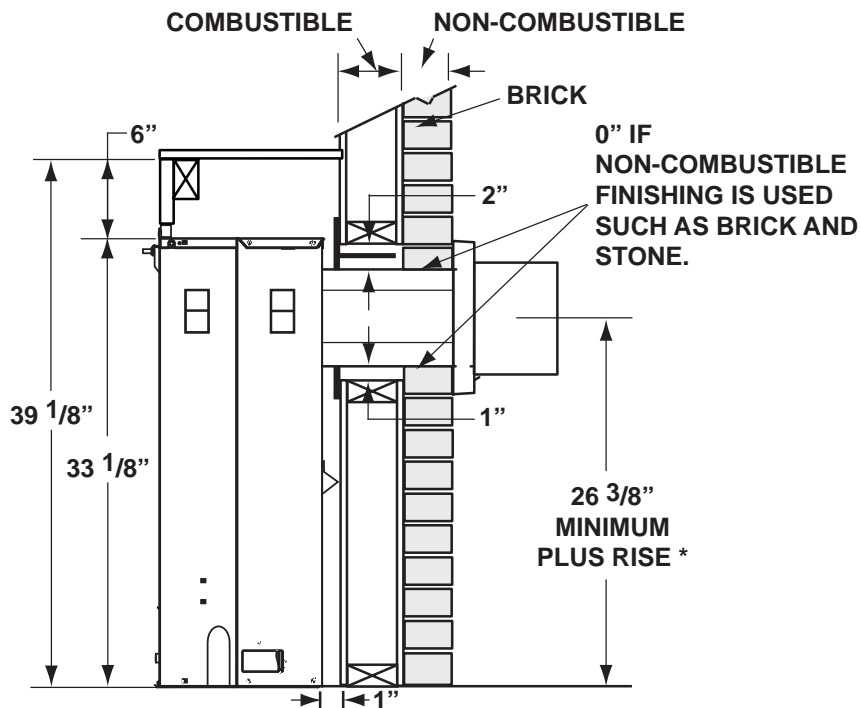

* See "VENTING" section

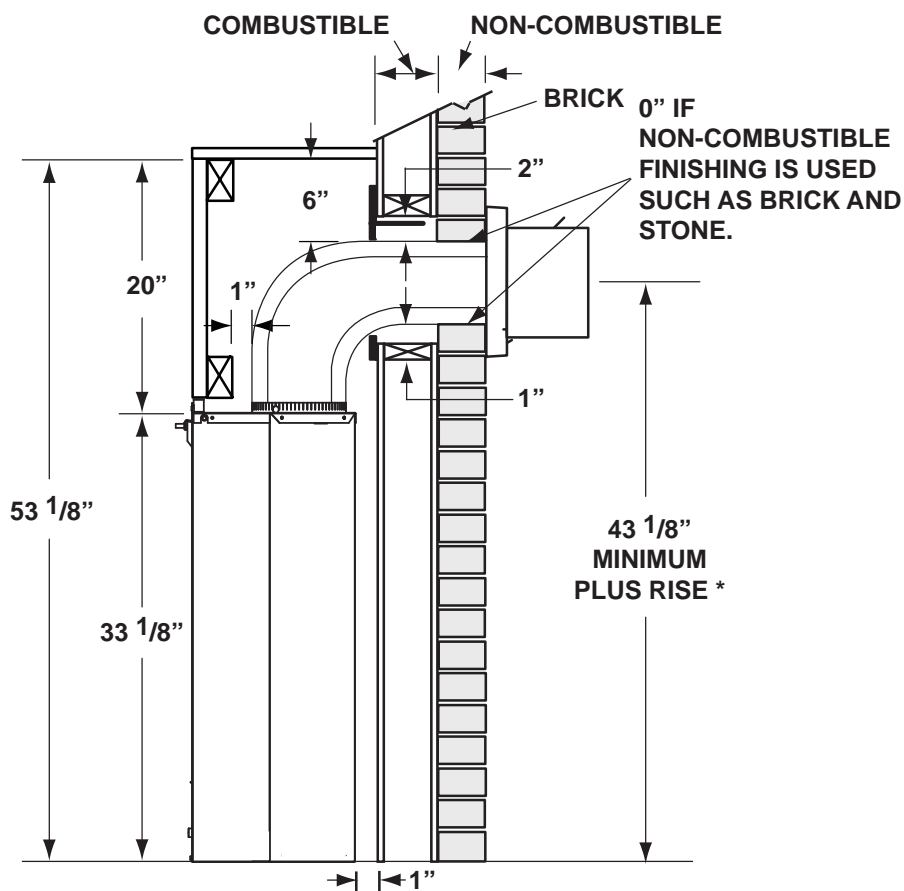

* See "VENTING" section

The appliance requires a minimum enclosure height of 53 1/8" for a top vent, and 39 1/8" for a rear vent. For temperature requirements, the enclosure space around and above the appliance must be left unobstructed.

4.3 MINIMUM MANTEL CLEARANCES

! WARNING

RISK OF FIRE, MAINTAIN ALL SPECIFIED AIR SPACE CLEARANCES TO COMBUSTIBLES. FAILURE TO COMPLY WITH THESE INSTRUCTIONS MAY CAUSE A FIRE OR CAUSE THE APPLIANCE TO OVERHEAT. ENSURE ALL CLEARANCES (I.E. BACK, SIDE, TOP, VENT, MANTEL, FRONT, ETC.) ARE CLEARLY MAINTAINED.

WHEN USING PAINT OR LACQUER TO FINISH THE MANTEL, THE PAINT OR LACQUER MUST BE HEAT RESISTANT TO PREVENT DISCOLOURATION.

Mantel clearance can vary according to the mantel depth. Use the graph to help evaluate the clearance needed.

Combustible materials must be installed flush with the front of the appliance but must not cover any of the black face-area of the appliance. Non-combustible material (brick, stone or ceramic tile) may protrude past the face of the appliance.

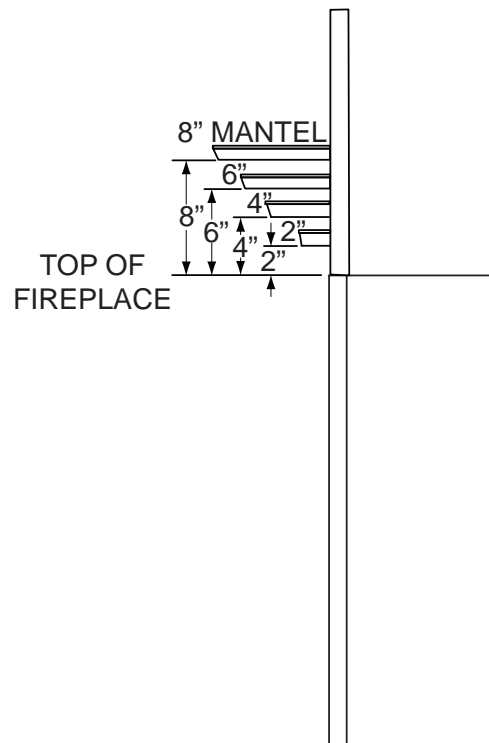
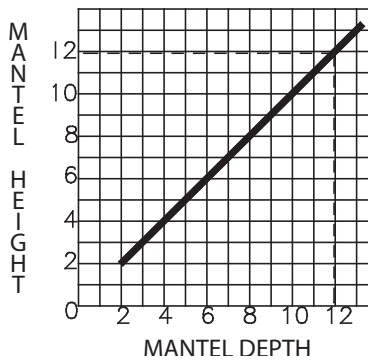

5.0 ELECTRICAL CONNECTION

! WARNING

DO NOT USE THIS APPLIANCE IF ANY PART HAS BEEN UNDER WATER. CALL A QUALIFIED SERVICE TECHNICIAN IMMEDIATELY TO HAVE THE APPLIANCE INSPECTED FOR DAMAGE TO THE ELECTRICAL CIRCUIT.

RISK OF ELECTRICAL SHOCK OR EXPLOSION. DO NOT WIRE 110V TO THE VALVE OR TO THE APPLIANCE WALL SWITCH. INCORRECT WIRING WILL DAMAGE CONTROLS.

ALL WIRING SHOULD BE DONE BY A QUALIFIED ELECTRICIAN AND SHALL BE IN COMPLIANCE WITH LOCAL CODES. IN THE ABSENCE OF LOCAL CODES, USE THE CURRENT CSA22.1 CANADIAN ELECTRIC CODE IN CANADA OR THE CURRENT NATIONAL ELECTRIC CODE ANSI/NFPA NO. 70 IN THE UNITED STATES.

ALWAYS LIGHT THE PILOT WHETHER FOR THE FIRST TIME OR IF THE GAS SUPPLY HAS RAN OUT, WITH THE GLASS DOOR OPENED OR REMOVED.

It is necessary to hard wire this appliance. Permanently framing the appliance with an enclosure, requires the appliance junction box to be hard wired.

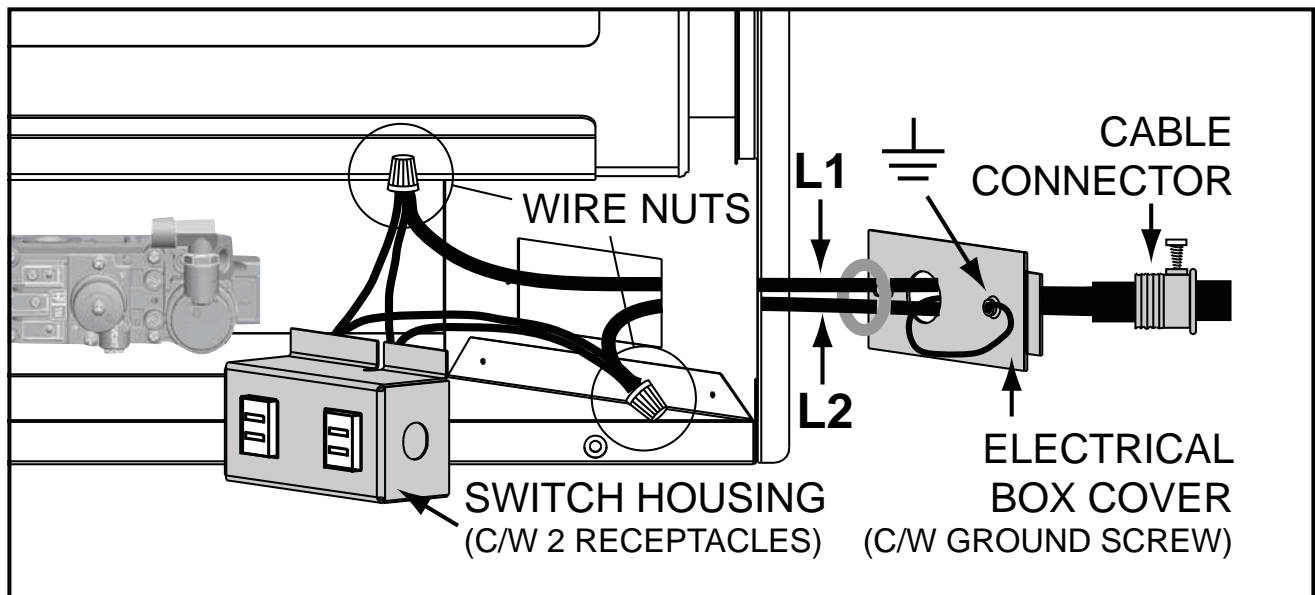

6.0 WIRING DIAGRAM

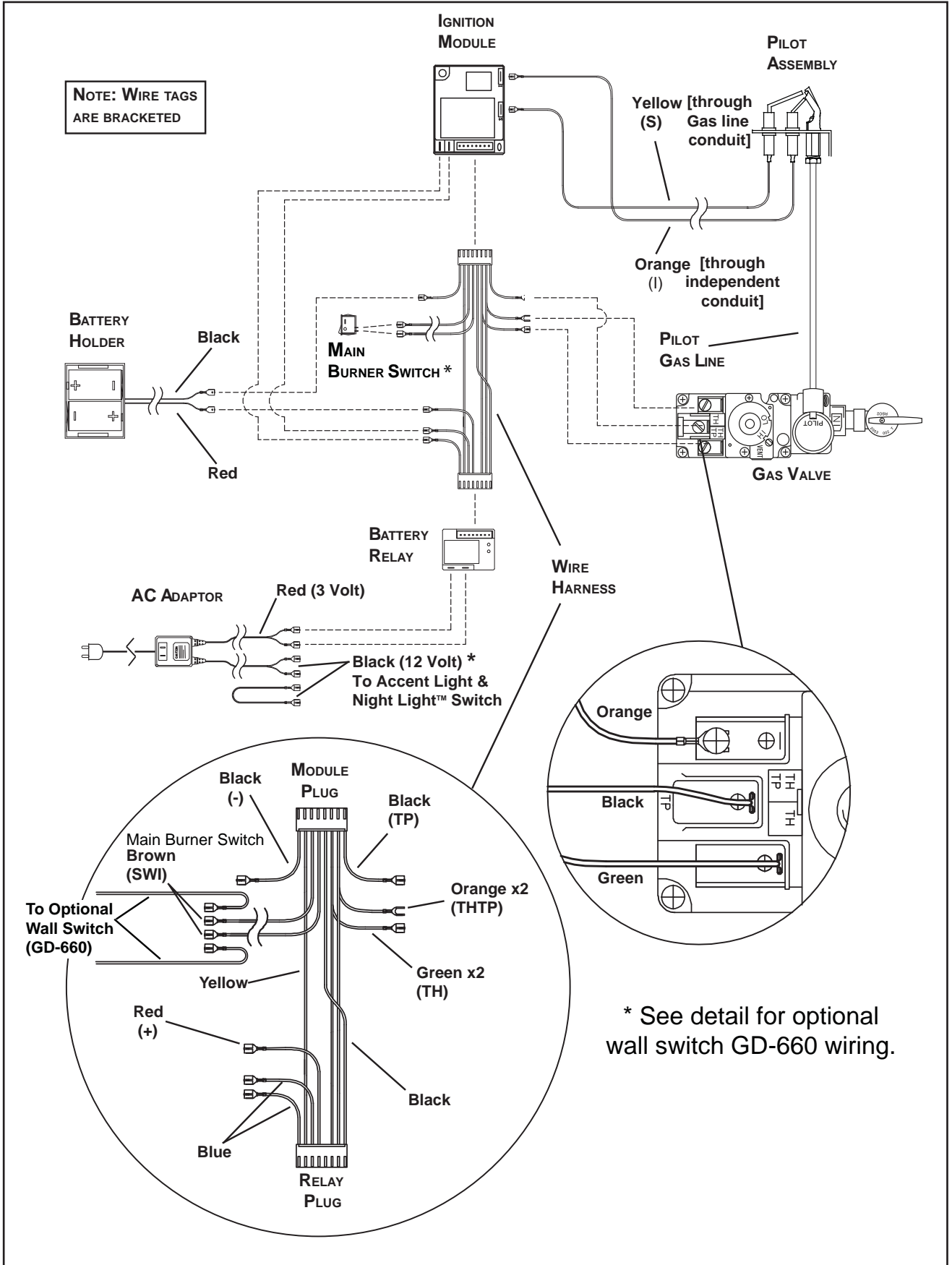

7.0 FINISHING

7.1 GLASS DOOR

REMOVAL:

- Before the glass door can be removed, the decorative front must be removed.
- The glass door is secured to the top and front bottom edges of the firebox with four spring latches. Pull forward on the latches and away from the door to release.
- Slide the door forward off its support.

INSTALLATION:

- Rest the door on the door support, centred on the firebox opening.
- Engage all four spring handles.

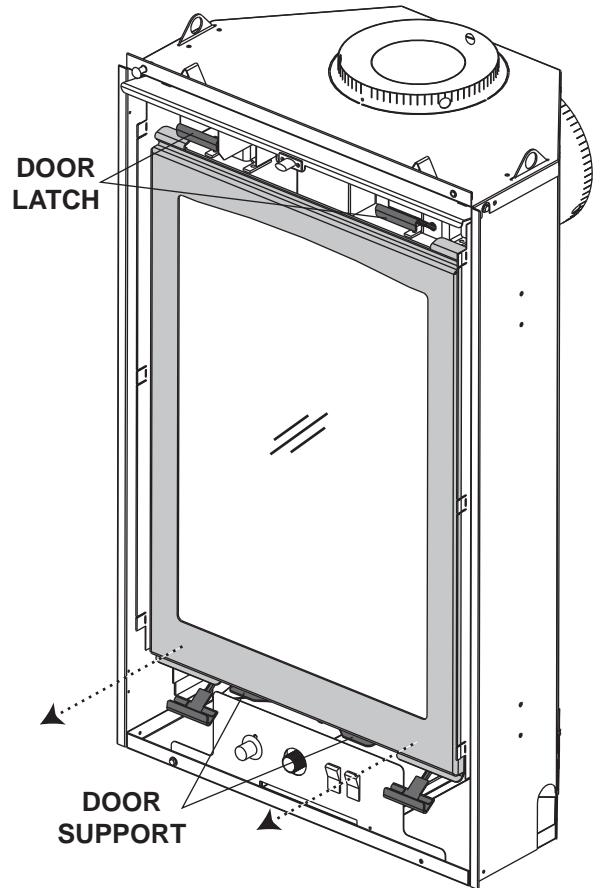

7.2 DOOR GLASS REPLACEMENT

! WARNING
DO NOT USE SUBSTITUTE MATERIALS.
GLASS MAY BE HOT, DO NOT TOUCH GLASS UNTIL COOLED.
CARE MUST BE TAKEN WHEN REMOVING AND DISPOSING OF ANY BROKEN GLASS OR DAMAGED COMPONENTS. BE SURE TO VACUUM UP ANY BROKEN GLASS FROM INSIDE THE APPLIANCE BEFORE OPERATION.
DO NOT OPERATE THE APPLIANCE WITH THE GLASS DOOR REMOVED, CRACKED OR BROKEN.

- Place the door frame face down careful not to scratch the paint.
- Center the gasketed glass inside the door frame with the thick side of the gasket facing up.
- Bend the glass retainers located along the edge of the door frame over the gasket holding the glass in place. Careful not to break the glass.

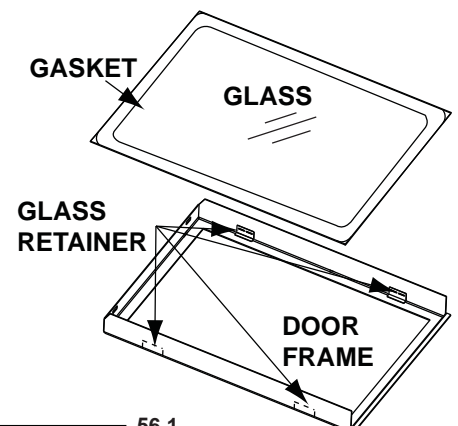

7.3 LOG PLACEMENT

! WARNING

LOGS MUST BE PLACED IN THEIR EXACT LOCATION IN THE APPLIANCE. DO NOT MODIFY THE PROPER LOG POSITIONS, SINCE APPLIANCE MAY NOT FUNCTION PROPERLY AND DELAYED IGNITION MAY OCCUR.

THE LOGS ARE FRAGILE AND SHOULD BE HANDLED WITH CARE.

In order to assemble the log set, the glass door must be removed, see "GLASS DOOR INSTALLATION AND REMOVAL" section.

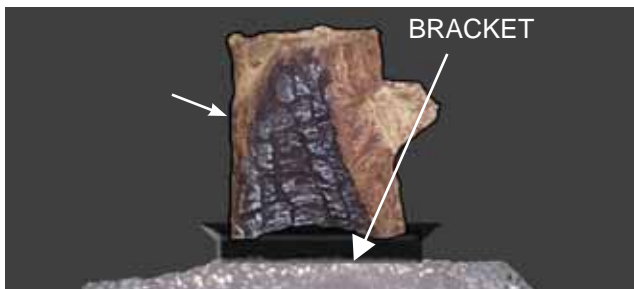

7.3.1 Place the rear log as shown, ensuring the holes on the underside are placed onto the 2 pins of the log support.

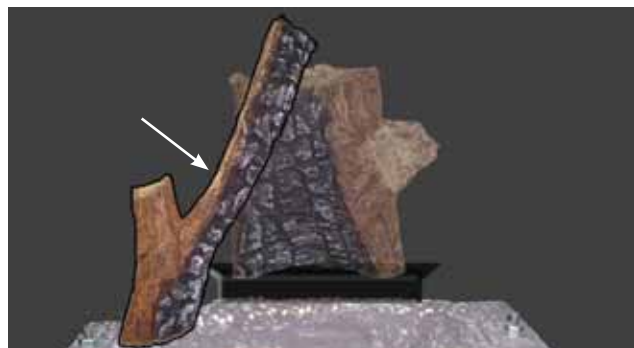

7.3.2 Place the left log as shown, ensuring the hole on the underside is placed onto the burner pin. This will rest on the left side of the rear log.

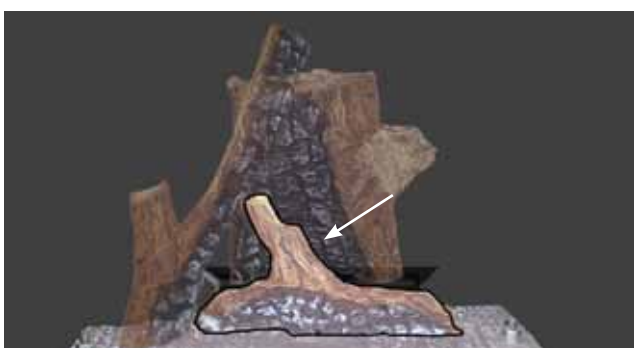

7.3.3 Place the center log as shown, ensuring the holes on the underside are placed onto the two centre pins.

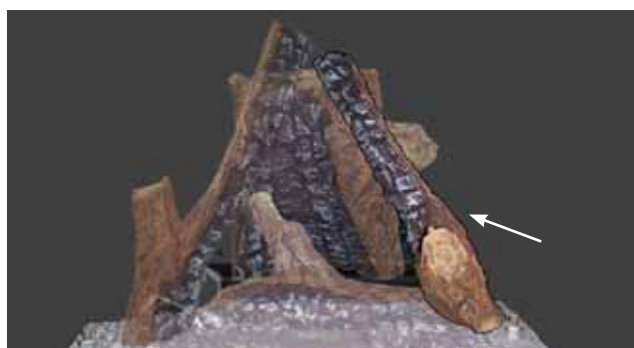

7.3.4 Place the hole in the underside of the right log onto the locating pin, on the burner base and rests against the rear log as shown.

7.3.5 Re-install the glass door.

7.4 CHARCOAL EMBERS

Randomly place the charcoal embers along the front and sides of the log support tray in a realistic manner.

Fine dust found in the bottom of the bag should not be used.

NOTE: Charcoal embers are not to be placed on the burner.

32.1

7.5 VERMICULITE

Sprinkle vermiculite around the charcoal embers.

NOTE: Vermiculite is not to be placed on the burner.

33.1

7.6 GLOWING EMBERS

Tear the embers into pieces and place along the burner ports covering all of the burner. Care should be taken to shred the embers into thin, small irregular pieces as only the exposed edges of the fibre hairs will glow. The ember material will only glow when exposed to direct flame; however, care should be taken to not block the burner ports.

Blocked burner ports can cause an incorrect flame pattern, carbon deposits and delayed ignition. Phazer™ logs glow when exposed to direct flame. Use only certified "glowing embers" and Phazer™ logs available from your Napoleon® dealer.

7.7 LOGO PLACEMENT

Remove the backing of the logo supplied and place on the glass viewing door, as indicated.

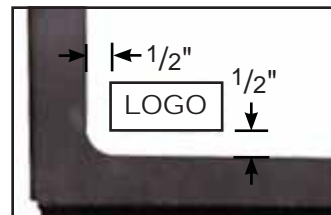

7.8 FRONT FACING AND INSET KIT INSTALLATION

! WARNING

THE COMPONENTS IN THIS KIT ARE HEAVY, USE CARE WHEN LIFTING AND ENSURE THEY ARE FIRMLY SECURED ONCE INSTALLED.

THIS FRONT FACING DOES NOT REPLACE THE MAIN GLASS DOOR. DO NOT OPERATE WITHOUT THE MAIN GLASS DOOR INSTALLED.

THE FRONT FACING CAN SIT FLUSH WITH A COUNTER, FLOOR, OR HEARTH.



7.8.1 Secure the insets ① ② and screens ③ to the front facing ⑤ with the lock tooth washers and hex nuts supplied.

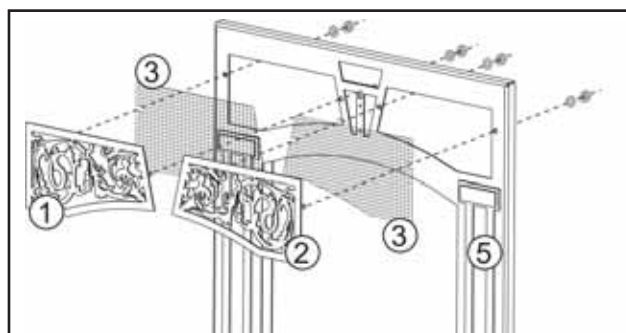

7.8.2 Install the turn button ⑦ to the face of the firebox using the 2 flat head screws supplied.

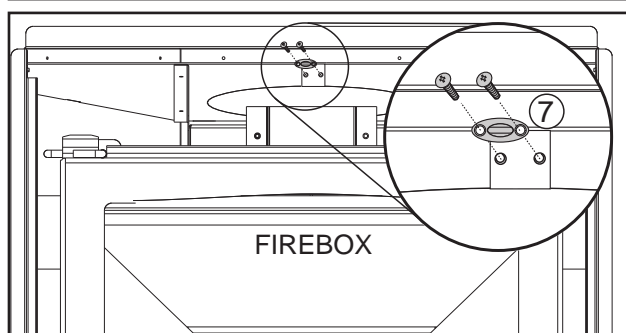

- 7.8.3** Hook the bottom of the front facing ⑤ on the bottom lip of the firebox. Pivot the front facing against the firebox and insert the head of the turn button ⑦ through the slot in the front facing. Secure by turning the head of the turn button 1/4 turn.

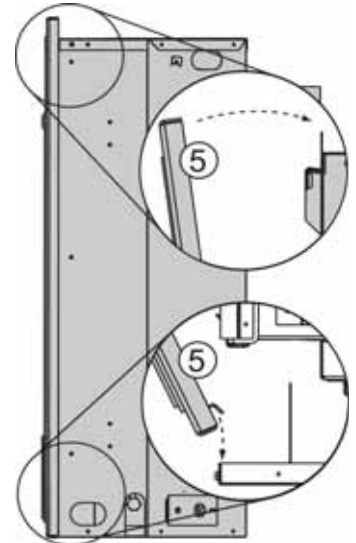

- 7.8.4** Clip the keystone ⑥ over the band of material and centre on the magnet.

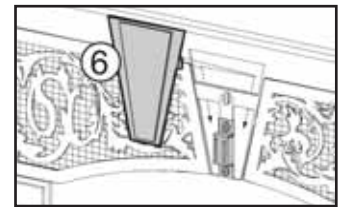

- 7.8.5** While angling the bottom inset, insert the side tabs on the bottom inset ④ behind the side edges of the control panel opening.

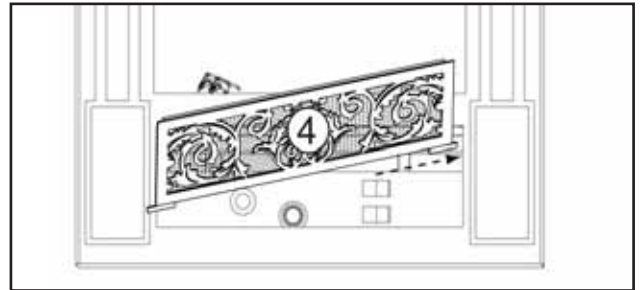

- 7.8.6** Close the bottom inset assembly ④ against the magnet to hold closed.

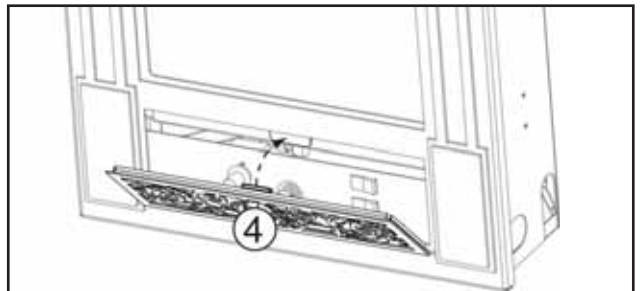

8.0 OPTIONAL BLOWER INSTALLATION

! WARNING

RISK OF FIRE AND ELECTRICAL SHOCK.

TURN OFF THE GAS AND ELECTRICAL POWER BEFORE SERVICING THIS APPLIANCE.

USE ONLY WOLF STEEL APPROVED OPTIONAL ACCESSORIES AND REPLACEMENT PARTS WITH THIS APPLIANCE. USING NON-LISTED ACCESSORIES (BLOWERS, DOORS, LOUVRES, TRIMS, GAS COMPONENTS, VENTING COMPONENTS, ETC.) COULD RESULT IN A SAFETY HAZARD AND WILL VOID THE WARRANTY AND CERTIFICATION.

ENSURE THAT THE FAN'S POWER CORD IS NOT IN CONTACT WITH ANY SURFACE OF THE APPLIANCE TO PREVENT ELECTRICAL SHOCK OR FIRE DAMAGE. DO NOT RUN THE POWER CORD BENEATH THE APPLIANCE.

ELECTRICAL INSTALLATION TO BE DONE BY A QUALIFIED INSTALLER and must be connected and grounded in accordance with local codes. In the absence of local codes, use the current CSA C22.1 Canadian Electrical Code in Canada or the current ANSI/NFPA 70 National Electrical Code in the United States.

If an optional blower is to be used, the blower must be connected to the main power supply. Route a grounded 14 gauge 2-wire power cable to the junction box and ground. At the point where the cable enters the junction box, a conduit connector must be provided.

8.0.1 Remove the two screws that secure the control panel to the front of the unit.

8.0.2 Connect the black and red wires of the wire harness to the prongs on the blower.

8.0.3 Connect the white and black wires of the wire harness to the prongs on the thermodisc.

8.0.4 Place the thermal switch assembly onto the stud located at the lower left of the firebox and behind the support bracket.

8.0.5 Connect the wiring for the variable speed switch.

8.0.6 Insert the blower assembly into the left side under the firebox, slide into the clip and place onto the same stud used for the thermal switch assembly. Secure with the lock washer and wing nut supplied. Ensure that the blower does not touch the base of the firebox, any wiring or controls. Ensure that the thermal switch is touching the wall of the firebox.

HINT: Rest the thermal disk assembly forward against the support bracket.

8.0.7 Place the variable speed switch into position and secure with the pal nut supplied. Reinstall the control panel and install the variable speed switch knob.

NOTE: Plug into the receptacle on the right side of the unit.

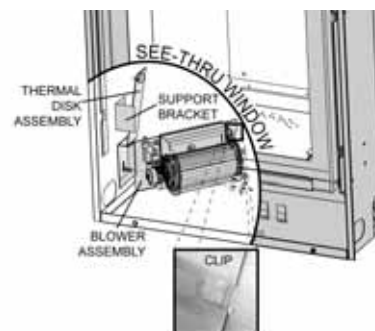
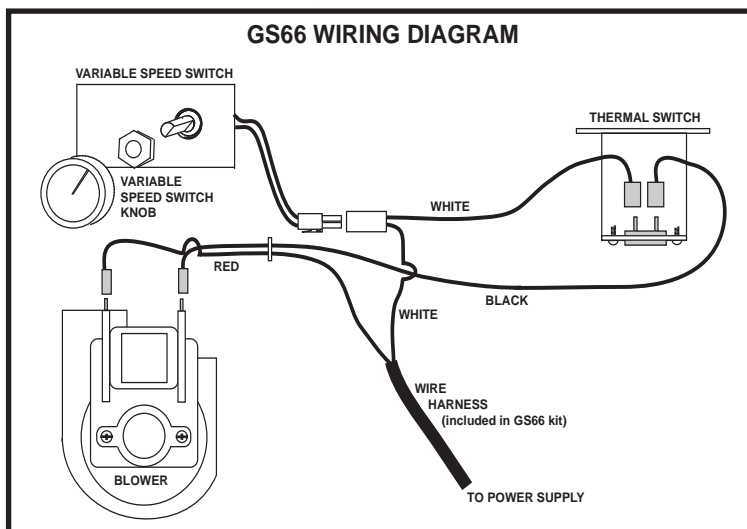
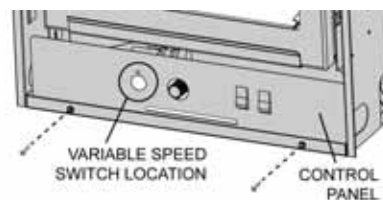

9.0 OPERATION

! WARNING

IF YOU DO NOT FOLLOW THESE INSTRUCTIONS EXACTLY, A FIRE OR EXPLOSION MAY RESULT CAUSING PROPERTY DAMAGE, PERSONAL INJURY OR LOSS OF LIFE.

ALWAYS LIGHT THE PILOT WHETHER FOR THE FIRST TIME OR IF THE GAS SUPPLY HAS RUN OUT WITH THE GLASS DOOR OPENED OR REMOVED.

Ensure that a continuous gas flow is at the burner before installing the door. When lit for the first time, the appliance will emit an odor for a few hours. This is a normal temporary condition caused by the "burn-in" of paints and lubricants used in the manufacturing process and will not occur again. After extended periods of non-operation such as following a vacation or a warm weather season, the appliance may emit a slight odor for a few hours. This is caused by dust particles in the heat exchanger burning off. In both cases, open a window to sufficiently ventilate the room.

FOR YOUR SAFETY READ BEFORE LIGHTING:

- A. This appliance is equipped with an ignition device which automatically lights the pilot. Do not try to light by hand.
- B. Before operating smell all around the appliance area for gas and next to the floor because some gas is heavier than air and will settle on the floor.
- C. Use only your hand to turn the gas control knob. Never use tools. If the knob will not turn by hand, do not try to repair it. Call a qualified service technician. Forced or attempted repair may result in a fire or explosion.
- D. Do not use this appliance if any part has been under water. Immediately call a qualified service technician to inspect the appliance and replace any part of the control system and any gas control which has been under water.

WHAT TO DO IF YOU SMELL GAS:

- Turn off all gas to the appliance.
- Open windows.
- Do not try to light any appliance.
- Do not touch any electric switch; do not use any phone in your building.
- Immediately call your gas supplier from a neighbor's phone. Follow the gas supplier's instructions.
- If you cannot reach your gas supplier, call the fire department.

LIGHTING INSTRUCTIONS:

1. Stop! Read the above safety information on this label.
2. Turn remote wall switch to off position.
3. Turn off all electrical power to the appliance and remove batteries.
4. This appliance is equipped with an ignition device which automatically lights the pilot. Do not try to light the pilot by hand.
5. Turn manual shutoff valve clockwise to off.
6. Open the glass door.
7. Wait five (5) minutes to clear out any gas. If you smell gas including near the floor, STOP! Follow "B" in the above safety information on this label. If you don't smell gas go to the next step.
8. Close the glass door.
9. Turn manual shutoff valve counter-clockwise to on.
10. Turn on all electrical power to the appliance and re-install batteries.
11. Turn on remote wall switch to on position.
12. If appliance will not operate, follow instructions "TO TURN OFF GAS" and call your service technician or gas supplier.

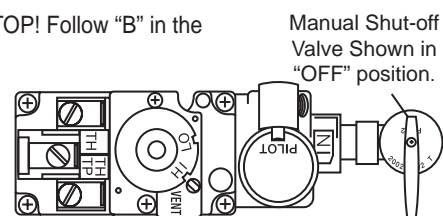

TO TURN OFF GAS

1. Turn off remote wall switch to the appliance.
2. Turn off all electrical power to the appliance if service is to be performed.
3. Turn manual shutoff valve clockwise to off. Do not force.

47.6

9.1 CONTROL FUNCTIONS

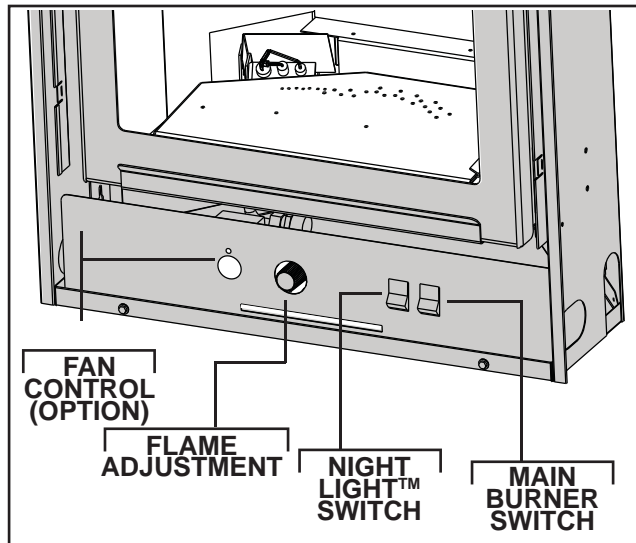
**MAIN BURNER SWITCH**

This switch turns the Main Burner on and off.

FLAME ADJUSTMENT

Turn this knob clockwise or counter-clockwise to adjust the main burner flame height.

NIGHT LIGHT™ SWITCH

This switch turns the Night Light™ on and off.

FAN CONTROL OPTION

If installed this switch will turn on and off the power to the blower and control the fan speed. There is also a thermally activated switch that will only let the blower come on once the appliance has reached a comfortable temperature.

10.0 ADJUSTMENTS

10.1 PILOT INJECTOR AND ORIFICE REPLACEMENT

 **WARNING**

THIS INSTALLATION SHOULD BE DONE BY A QUALIFIED INSTALLER AND SHALL BE IN COMPLIANCE WITH LOCAL CODES. IN THE ABSENCE OF LOCAL CODES, USE THE CURRENT CAN1-B149 INSTALLATION CODE IN CANADA, OR THE CURRENT NATIONAL FUEL GAS CODE ANSI Z223.1 IN THE UNITED STATES.

- 10.1.1** Turn off the electrical and gas supply to the appliance.
- 10.1.2** Remove the cast front, glass viewing door and log set.
- 10.1.3** Remove the 2 securing screws. Slide the burner assembly to the right and lift out.
- 10.1.4** Using a deep 9/16" socket wrench, remove the main burner orifice. A 7/8" back-up wrench must be used on the manifold, located below the housing to ensure that the aluminum tubing does not twist or kink. Replace the correct burner orifice using pipe thread compound.
- 10.1.5** Loosen nut and replace with appropriate injector
- 10.1.6** Reinstall the burner ensuring that the Venturi tube fits over the orifice.
NOTE: Check and adjust, if necessary, the primary air to 1/16" for propane and 1/32" for natural gas. Replace the screws.
- 10.1.7** Turn on the gas supply and check for gas leaks by brushing on a soap and water solution.
DO NOT USE OPEN FLAME.
- 10.1.8** Replace the log set. Then light the pilot and main burner to ensure that the gas lines have been purged.
- 10.1.9** Replace the glass viewing door and cast front. Turn on the electrical supply to the appliance.

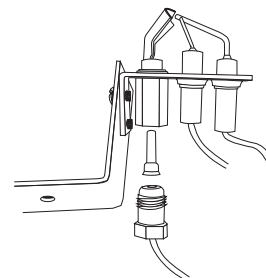
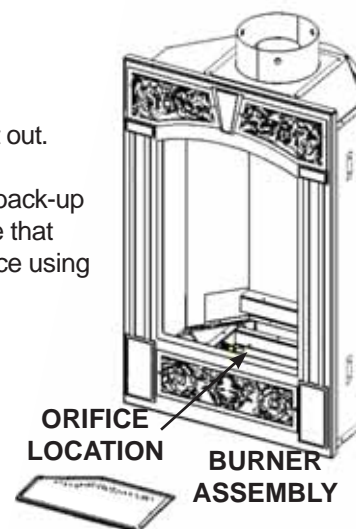

Purge all gas lines with the glass door removed. Assure that a continuous flow is at the burner before re-installing the door.

10.2 PRESSURE CHECK

Check Pressure Readings:

Inlet pressure can be checked by turning screw (A) counter-clockwise 2 or 3 turns and then placing pressure gauge tubing over the test point. Gauge should read 7" (minimum 4.5") water column for natural gas or 13" (11" minimum) water column for propane. Check that main burner is operating on "HI".

Outlet pressure can be checked the same as above using screw (B). Gauge should read 3.5" water column for natural gas or 10" water column for propane. Check that main burner is operating on "HI".

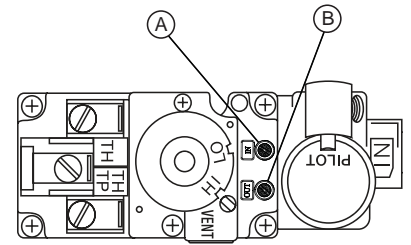

AFTER TAKING PRESSURE READINGS, BE SURE TO TURN SCREWS CLOCKWISE FIRMLY TO RESEAL. DO NOT OVERTORQUE.

Leak test with a soap and water solution.

39.5

10.3 FLAME ADJUSTMENT

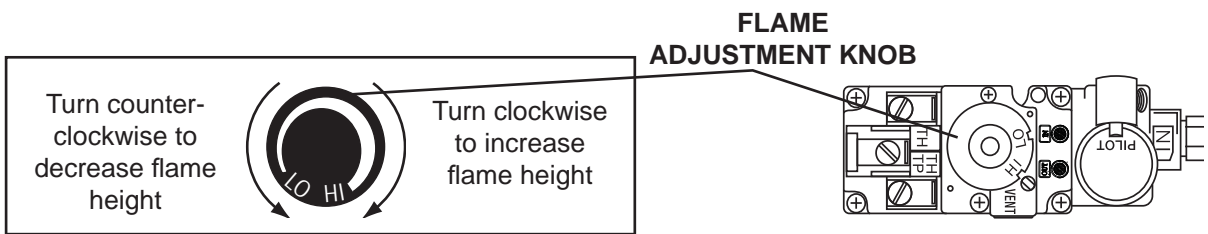

10.4 FLAME CHARACTERISTICS

It's important to periodically perform a visual check of the pilot and burner flames. Compare them to the illustrations provided. If any flames appear abnormal call a service person.

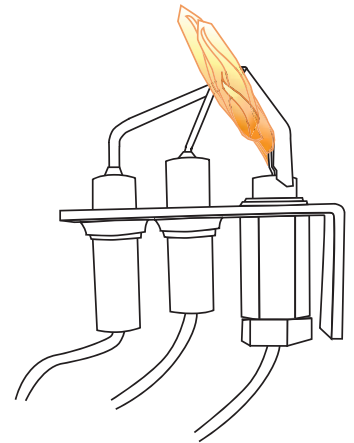

54.3

10.5 VENTURI ADJUSTMENT

This appliance has an air shutter that has been factory set open according to the chart below:

Closing the air shutter will cause a more yellow flame, but can lead to carboning. Opening the air shutter will cause a more blue flame, but can cause flame lifting from the burner ports. The flame may not appear yellow immediately; allow 15 to 30 minutes for the final flame color to be established.

AIR SHUTTER ADJUSTMENT MUST ONLY BE DONE BY A QUALIFIED INSTALLER!

GD19	
NG	1/32"
LP	1/16"



49.2

11.0 MAINTENANCE



TURN OFF THE GAS AND ELECTRICAL POWER BEFORE SERVICING THE APPLIANCE.

CAUTION: Label all wires prior to disconnection when servicing controls. Wiring errors can cause improper and dangerous operation. Verify proper operation after servicing. This fireplace and its venting system should be inspected before use and at least annually by a qualified service person. The fireplace area must be kept clear and free of combustible materials, gasoline or other flammable vapors and liquids. The flow of combustion and ventilation air must not be obstructed.

1. In order to properly clean the burner and pilot assembly, remove the logs, rocks and/or glass to expose both assemblies.
2. Keep the control compartment, media, burner, air shutter opening and the area surrounding the logs clean by vacuuming or brushing, at least once a year.
3. Check to see that all burner ports are burning. Clean out any of the ports which may not be burning or are not burning properly.
4. Check to see that the pilot flame is large enough to engulf the flame sensor and/or thermocouple / thermopile as well as reaches the burner.
5. Replace the cleaned logs, rocks or glass. Failure to properly position the media may cause carboning which can be distributed in the surrounding living area.
6. Check to see that the main burner ignites completely on all openings when turned on. A 5 to 10 second total light-up period is satisfactory. If ignition takes longer, consult your local authorized dealer / distributor.
7. Check that the gasketing on the sides, top and bottom of the door is not broken or missing. Replace if necessary.
8. If for any reason the vent air intake system is disassembled, re-install and re-seal per the instructions provided for the initial installation.

40.1

11.1 NIGHT LIGHT™ REPLACEMENT

11.1.1 BULB REPLACEMENT

The GD19 comes equipped with our "Night Light™". If in the event the lamp or lens needs to be replaced, follow these instructions.

- A. Turn off all electrical supply.
- B. Remove the front and door from the firebox.
- C. Unscrew the lens cover making sure the washer stays in place.
NOTE: Do not handle the lamp (bulb) with bare fingers, protect with a clean dry cloth.
- D. The lamp will pull straight out of the socket. Replace with Wolf Steel Ltd. parts only (W387-0009), as lamp and lens are special "high temperature" products.
- E. Replace lens with gasket, lens covers, attach wires to quick connects and replace the door when finished.
NOTE: The firebox must be sealed.

When re-assembling the light assembly, care must be taken. "Light Leakage" from above the cast doors may be noticed. The holes in the lamp housing are necessary for ventilation and must not be covered.



11.1.2 LENS ASSEMBLY INSTALLATION

- A. Remove the door from the firebox.
- B. Run the wires up through the lens hole.
- C. Align key hole with lens assembly.
- D. Snap into place.
- E. Replace light shields, attach the wires and replace the door to the firebox.



11.1.3 LENS ASSEMBLY REPLACEMENT

- A. Remove the front door and top shield from the firebox.
- B. Compress the retainer fins in with a screw driver while pressing firmly on the top of the light assembly.
- C. Once all the retainer fins are pushed in the lens assembly will snap out of place.



12.0 REPLACEMENTS

Contact your dealer or the factory for questions concerning prices and policies on replacement parts. Normally all parts can be ordered through your Authorized dealer / distributor.

FOR WARRANTY REPLACEMENT PARTS, A PHOTOCOPY OF THE ORIGINAL INVOICE WILL BE REQUIRED TO HONOUR THE CLAIM.

When ordering replacement parts always give the following information:

- Model & Serial Number of appliance
- Installation date of appliance
- Part number
- Description of part
- Finish

*** IDENTIFIES ITEMS WHICH ARE NOT ILLUSTRATED. FOR FURTHER INFORMATION, CONTACT YOUR AUTHORIZED DEALER.**

 **WARNING**

**FAILURE TO POSITION THE PARTS
IN ACCORDANCE WITH THIS
MANUAL OR FAILURE TO USE ONLY
PARTS SPECIFICALLY APPROVED
WITH THIS APPLIANCE MAY
RESULT IN PROPERTY DAMAGE OR
PERSONAL INJURY.**

41.1

COMMON COMPONENTS		
REF NO.	APPLIANCE	DESCRIPTION
1	W135-0322	LOG #1- REAR
2	W135-0324	LOG #2 - RIGHT
3	W135-0323	LOG #3 - LEFT
4	W135-0325	LOG #4 - CENTER
5	GL-662	LOG SET
6	W725-0032	DEXEN VALVE - NG
6	W725-0049	DEXEN VALVE - LP
7	W010-1653	PAN BURNER
8	W455-0087	#52 BURNER ORIFICE - NG
8	W455-0088	#60 BURNER ORIFICE - LP
9*	W455-0049	PILOT INJECTOR - LP
9*	W455-0071	PILOT INJECTOR - NG
10*	W720-0092	PILOT TUBE
11	W100-0069	PILOT ASSEMBLY - NG
11	W100-0093	PILOT ASSEMBLY - LP
12*	W385-0334	NAPOLEON® LOGO
13*	W660-0009	ON/OFF SWITCH
14*	W387-0009	HALOGEN BULB 5W
15*	W387-0010	HIGH TEMPERATURE LIGHT ASSEMBLY
16	W010-2180	GLASS AND GASKET
17	W225-0250	DOOR FRAME
18	W010-1777	FIRESTOP SPACER

ROOF TERMINAL KITS		
REF NO.	APPLIANCE	DESCRIPTION
GD-110 - 1/12 TO 7/12 PITCH		
19	W670-0006	AIR TERMINAL
20	W490-0073	4/7 INNER / OUTER SLEEVE
21	W010-0567	ROOF SUPPORT
22	W170-0063	STORM COLLAR
23	W263-0054	ROOF FLASHING
GD-111 - 8/12 TO 12/12 PITCH		
19	W670-0006	AIR TERMINAL
20	W490-0073	4/7 INNER / OUTER SLEEVE
21	W010-0567	ROOF SUPPORT
22	W170-0063	STORM COLLAR
24	W263-0055	ROOF FLASHING
GD-112 - FLAT ROOF		
19	W670-0006	AIR TERMINAL
20	W490-0073	4/7 INNER / OUTER SLEEVE
21	W010-0567	ROOF SUPPORT
22	W170-0063	STORM COLLAR
25	W263-0056	ROOF FLASHING
ACCESSORIES		
REF NO.	APPLIANCE	DESCRIPTION
26	GS66	BLOWER KIT
27*	W175-0266	CONVERSION KIT - NG-LP 0-4,500
27*	W175-0267	CONVERSION KIT - LP-NG 0-4,500
28	GD-301	HEAT GUARD
29*	W175-0001	4" COUPLER
30	GD201	PERISCOPE
31	FK19	FACING KIT, METALLIC BLACK FINISH
31	FK19PW	FACING KIT, PEWTER FINISH
32	VOIK	VICTORIAN ORNAMENTAL INSETS, METALLIC BLACK FINISH
32	VOISS	VICTORIAN ORNAMENTAL INSETS, SATIN CHROME
33*	W500-0033	MOUNTING VARIABLE SPEED SWITCH PLATE
34*	W660-0010B	REMOTE CONTROL ADVANTAGE
35*	W660-0026	BATTERY OPERATED TIMER
36*	PRP19	PORCELAIN REFLECTOR RADIANT PANEL KIT
37*	GD839KT	DECO BRICK KIT - SANDSTONE
38*	VS47KT	VENT SLEEVE
39*	GD-660	SWITCH & WIRE
40*	GD222	WALL TERMINAL
41*	W573-0002	HIGH TEMPERATURE SEALANT - RTV
42*	W573-0007	HIGH TEMPERATURE SEALANT - MILL PAC
43*	W500-0096	FIRESTOP SPACER
44*	W585-0072	VENT PIPE SHIELD
45*	W170-0063	VENT PIPE COLLAR

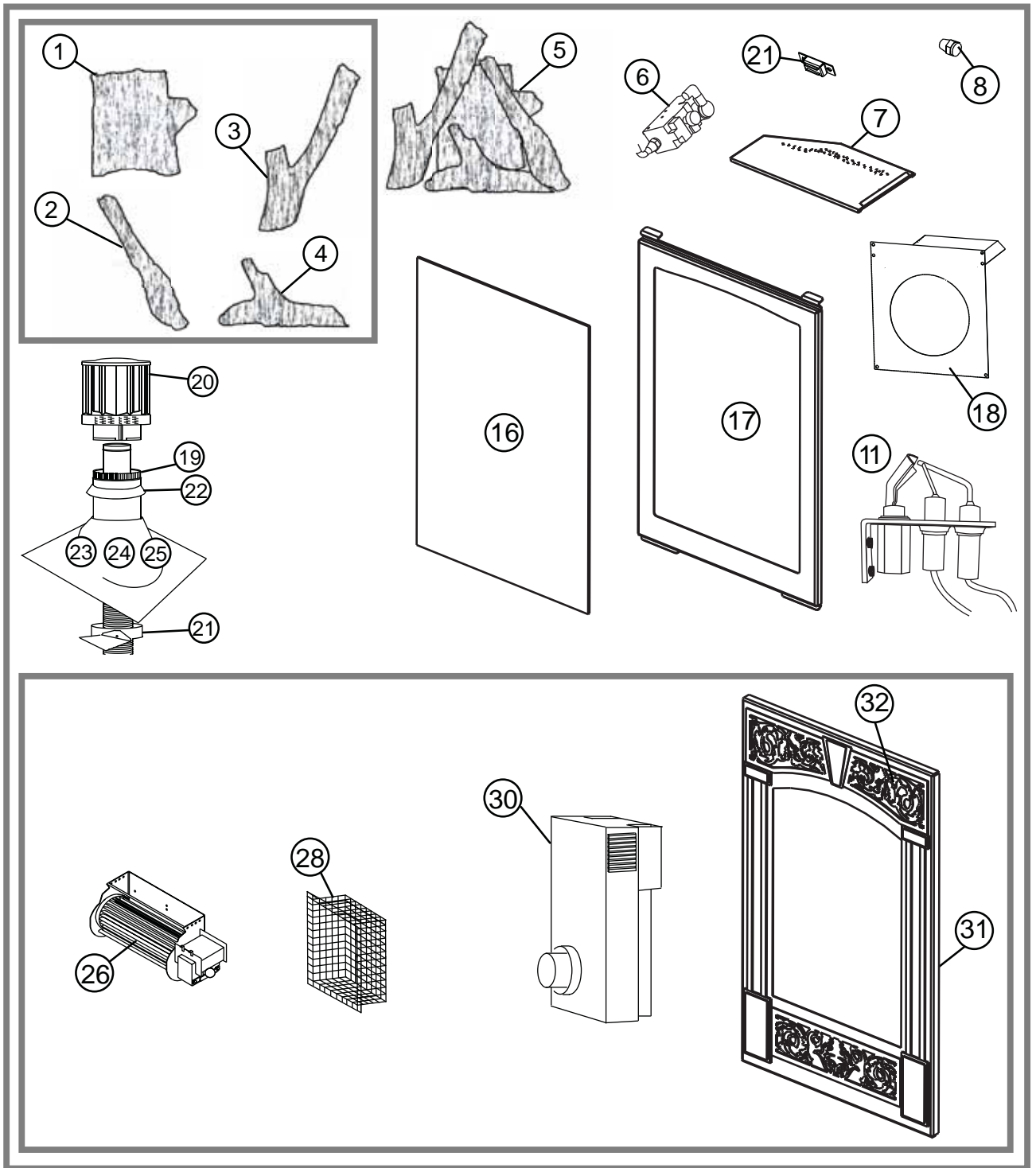

13.0 TROUBLE SHOOTING

 **WARNING**

ALWAYS LIGHT THE PILOT WHETHER FOR THE FIRST TIME OR IF THE GAS SUPPLY HAS RAN OUT, WITH THE GLASS DOOR OPEN OR REMOVED.

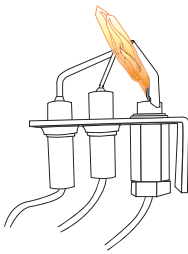
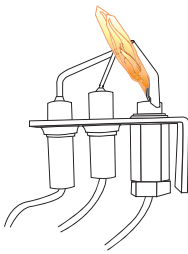
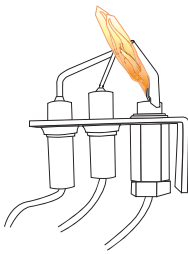
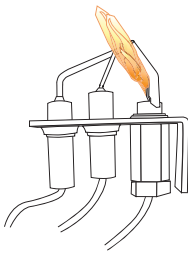
SYMPTOM	PROBLEM	TEST SOLUTION
Pilot will not light.	Wiring.	- Verify the "S" wire for the sensor and the "I" wire for the igniter are connected to the correct terminals (not reverse) on the module and pilot assembly.
	Loose connection.	- Verify no loose connections, electrical shorts in the wiring or ground out to any metal object.
	Module.	- Turn the ON/OFF switch to the "OFF" position. Remove the igniter wire "I" from the module. Place the ON/OFF switch to the "ON" position. Hold a grounded wire about 3/16" away from the "I" terminal on the module. If no spark the "I" terminal module must be replaced. If there is a spark the "I" terminal is fine. Inspect pilot assembly for a shorted wire or cracked insulator around the electrode.
Makes noise with no spark at pilot burner. 	Igniter Spark gap is incorrect.	- Spark gap of the igniter to the pilot should be .17" to 1/8"
	Pilot will not light.	Transformer.
Makes no noise with no spark at pilot burner. 	A shorted or loose Connection.	- Remove and reinstall the wiring harness that plugs into the module. Remove and verify continuity of each wire in wiring harness.
	Improper switch wiring.	- Troubleshoot the system with the simplest ON/OFF switch.
	Module is not grounded.	- Verify the value and pilot assemblies are properly grounded to the metal chassis of the fireplace or log set.
	Faulty module.	- Turn the ON/OFF switch to the "OFF" position. Remove the igniter wire "I" from the module. Place the ON/OFF switch to the "ON" position. Hold a grounded wire about 3/16" away from the "I" terminal on the module. If no spark the "I" terminal module must be replaced. If there is a spark the "I" terminal is fine. Inspect pilot assembly for a shorted wire or cracked insulator around the electrode.
	Pilot sparks but will not light.	Gas supply.
Carbon is being deposited on glass, logs or combustion chamber surfaces. 	Module is not grounded.	- Verify the value and pilot assemblies are properly grounded to the metal chassis of the fireplace or log set.
	Out of propane gas.	- Fill the tank.
	Air shutter has become blocked.	- Ensure air shutter opening is free of lint or other obstructions.
Flame is impinging on the logs or combustion chamber. 	Flame is impinging on the logs or combustion chamber.	- Check that the logs are correctly positioned. - Open air shutter to increase the primary air. - Check the input rate: check the manifold pressure and orifice size as specified by the rating plate values. - Check that the door gasketing is not broken or missing and that the seal is tight. - Check that both vent liners are free of holes and well sealed at all joints. - Check that minimum rise per foot has been adhered to for any horizontal venting.

SYMPTOM	PROBLEM	TEST SOLUTION
Continues to sparks and pilot lights, but main burner will not light.	Short or loose connection in sensor rod.	- Verify all connections. Verify the connections from the pilot assembly are tight; also verify these connections are not grounding out to any metal.
	Poor flame rectification or contaminated sensor rod.	- Verify the flame is engulfing the sensor rod. This will increase the flame rectification. Verify correct pilot orifice is installed and inlet gas specifications to manual. (Remember, the flame carries the rectification current, not the gas. If the flame lifts from pilot hood, the circuit is broken. A wrong orifice or too high of an inlet pressure can cause the pilot flame to lift.) The sensor rod may need cleaning.
	Poor grounding between pilot assembly and gas valve.	- Verify that the wire harness is firmly connected to module. Verify that the ceramic insulator around the sensor rod is not cracked, damaged, or loose. Verify the connection from the sensor rod to the sensor wire.
	Damaged pilot or dirty sensor rod.	- Clean sensor rod with an emery cloth to remove any contamination that may have accumulated on the sensor rod. Verify continuity with multimeter with ohms set at the lowest range.
Pilot lights Stops sparking / pilot remains lit but burner will not turn on.	Wiring / Connection.	- Inspect all wires, ensure good tight connections. Verify that all wiring is installed exactly as specified.
	Wiring harness.	- Inspect the wiring harness, and verify the harness is tightly connected to the module. Verify that you have 7 wires and they are connected in the right order.
	Module or Valve.	- Conduct the following test to verify if the problem is the module or valve. To measure voltages, turn multimeter to "DC" place the red lead from multimeter on the screw on the terminal block for the wire you are checking, touch black lead to ground (valve body). Importantly, a "Zero" volts reading does not automatically indicate a bad module, there may be too high resistance in the valve solenoid. Check the Green wire disconnected from valve that the voltage output from the module should be between 2 and 3 volts.
Exhaust fumes smelled in room, headaches.	Fireplace is spilling.	- Check all seals.
Flames are very aggressive.	Door is ajar.	- Tighten door clamps
	Venting action is too great.	- Restrict vent exit with restrictor plate. See Restricting Vents.
Main burner flame is a blue, lazy, transparent flame.	Blockage in vent.	- Remove blockage. In really cold conditions, ice buildup may occur on the terminal and should be removed as required.
	Compromised venting.	- Check venting system parameters (seal, length, rise, etc.)..
White / grey film forms.	Sulphur from fuel is being deposited on glass, logs or combustion chamber surfaces.	- Clean the glass with a recommended gas fireplace glass cleaner. DO NOT CLEAN GLASS WHEN HOT.
		- If deposits are not cleaned off regularly, the glass may become permanently marked.

42.7_2

